

Graine furnace with heater for heating of the second floor. The curbstone to the left of the stove can be lower on 25 sm. The outside environment conditionally is not shown. It can be executed from various materials at the request of the customer. Oven hardware from the Finnish firm Pisla. An output(exit) of gases in a round pipe, which on the drawing is not shown. The furnace is constructed in 2006 from oven elements of German firm [Wolfshöher Tonwerke](http://www.wolfshoehe.de)

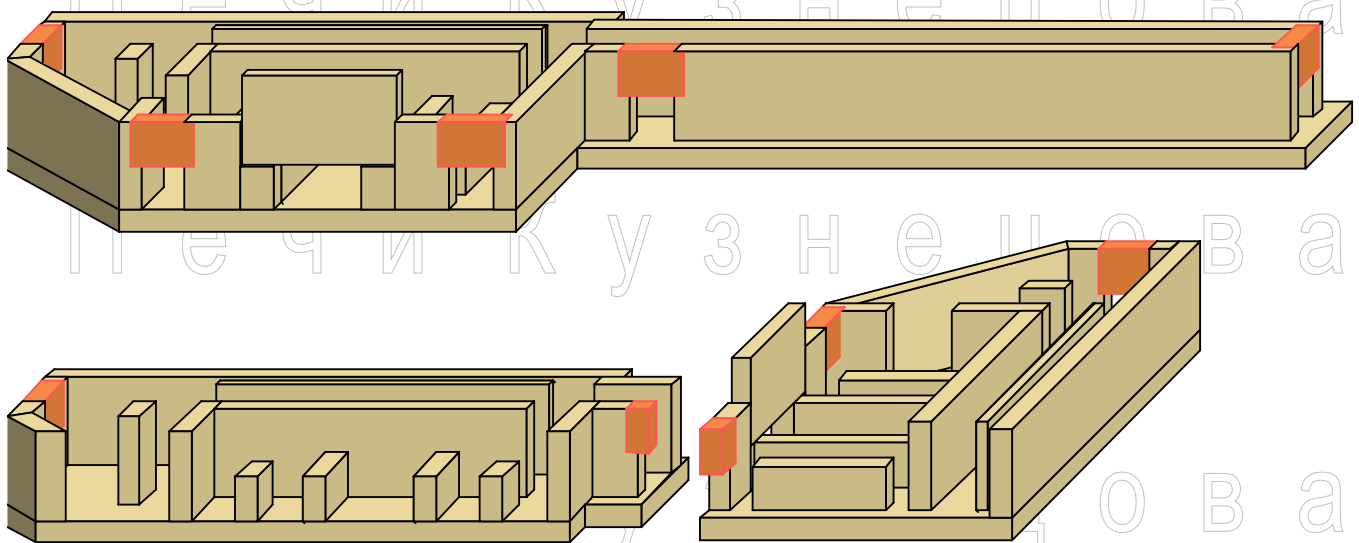

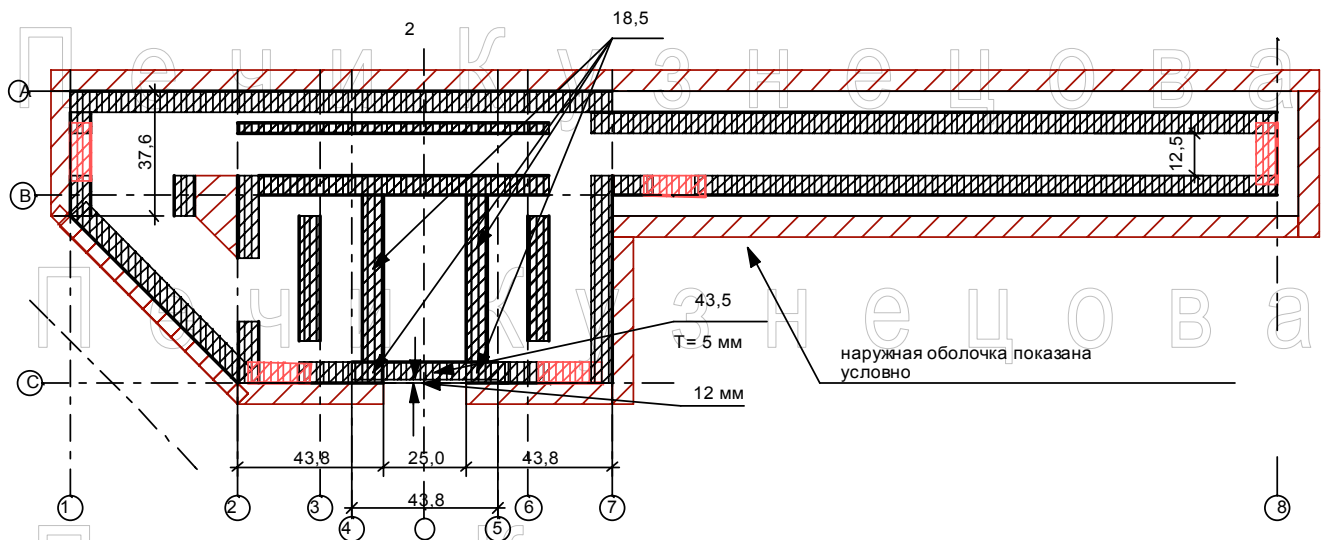

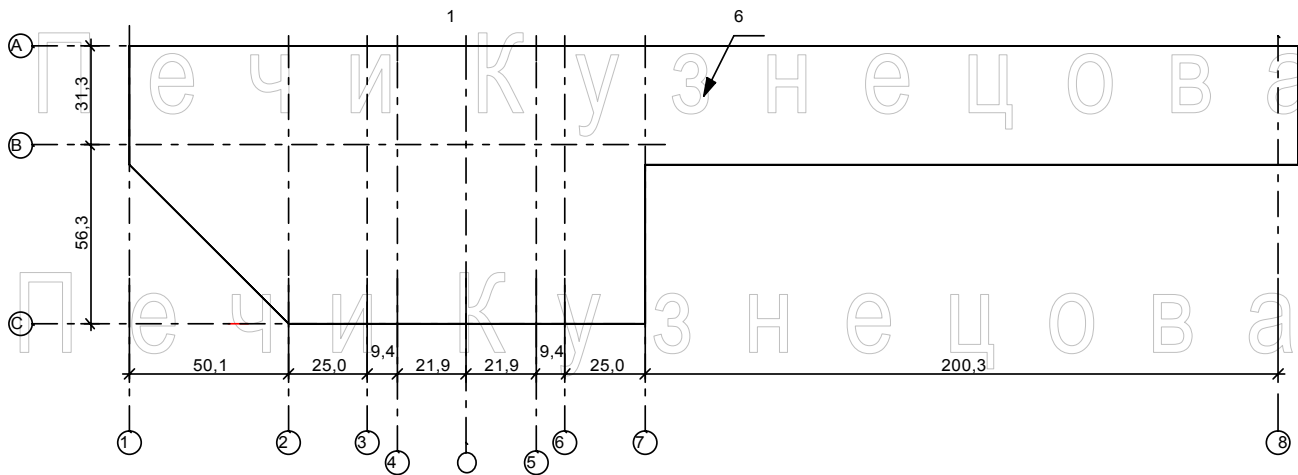

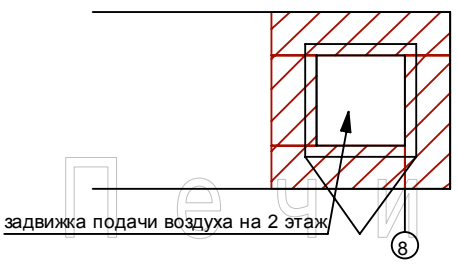
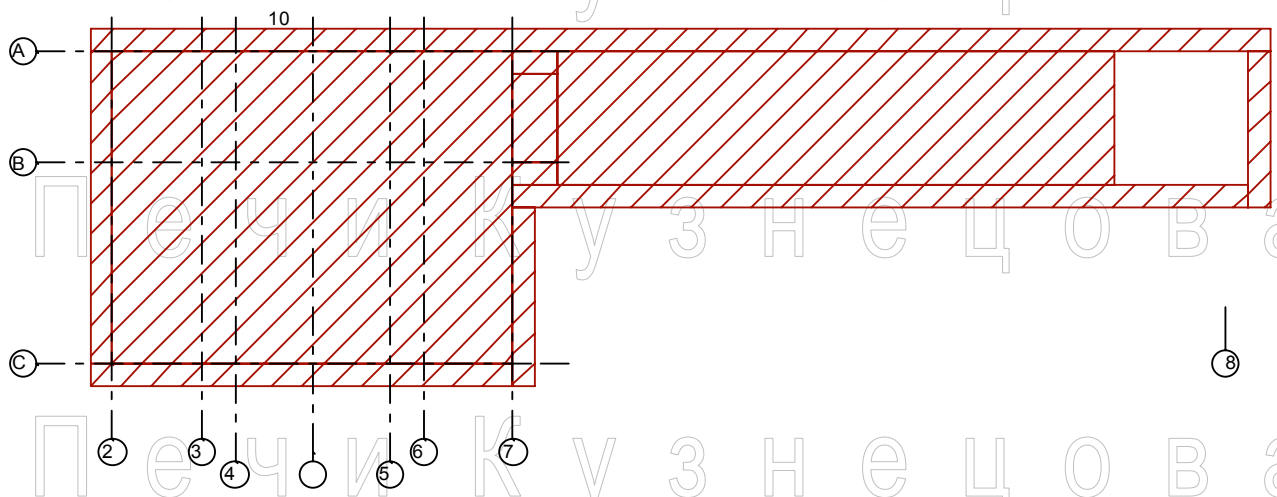
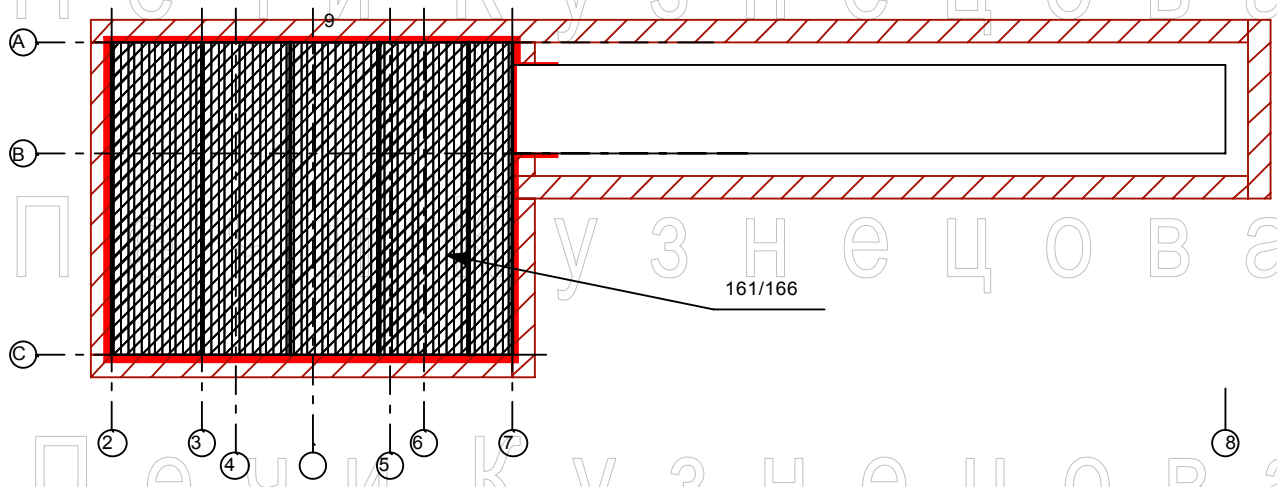
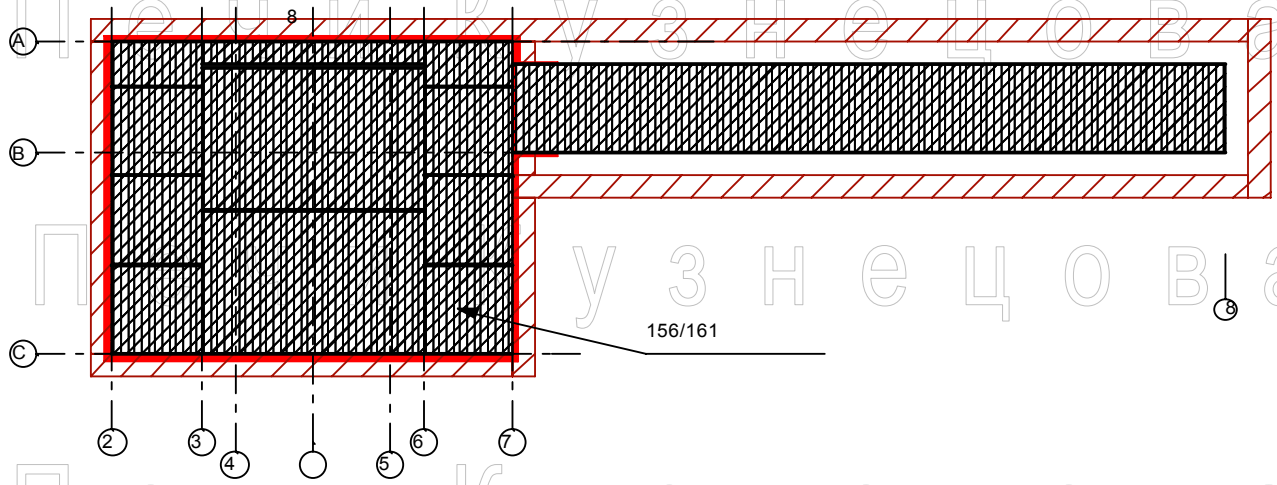
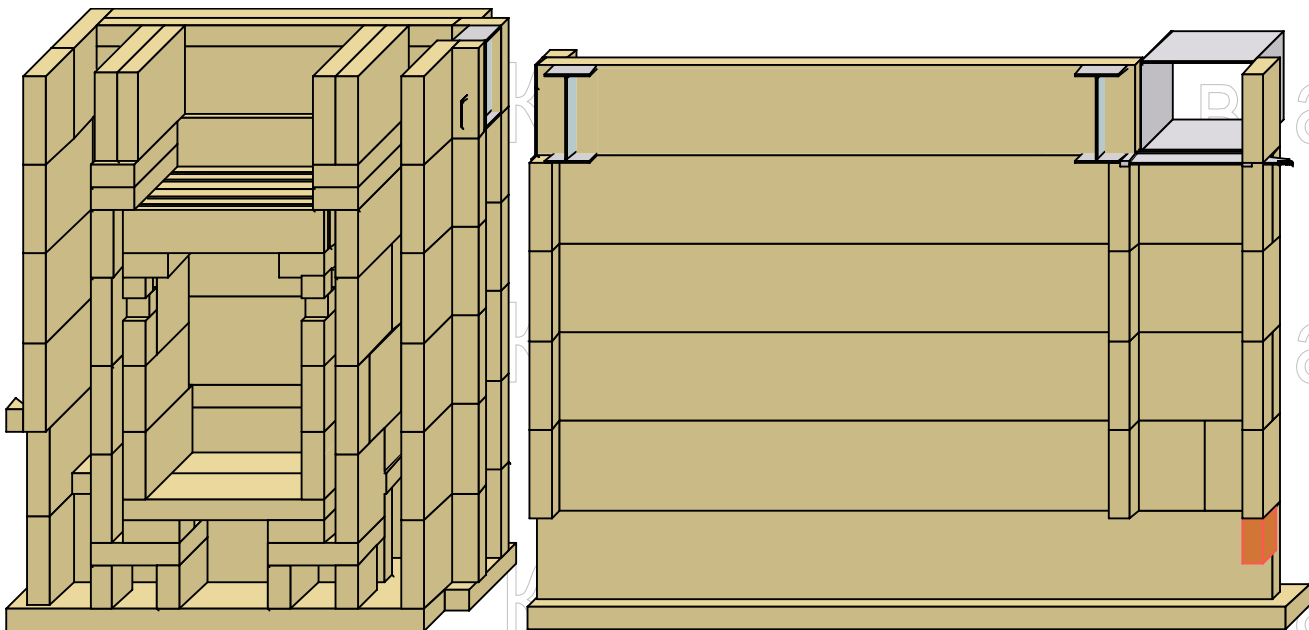
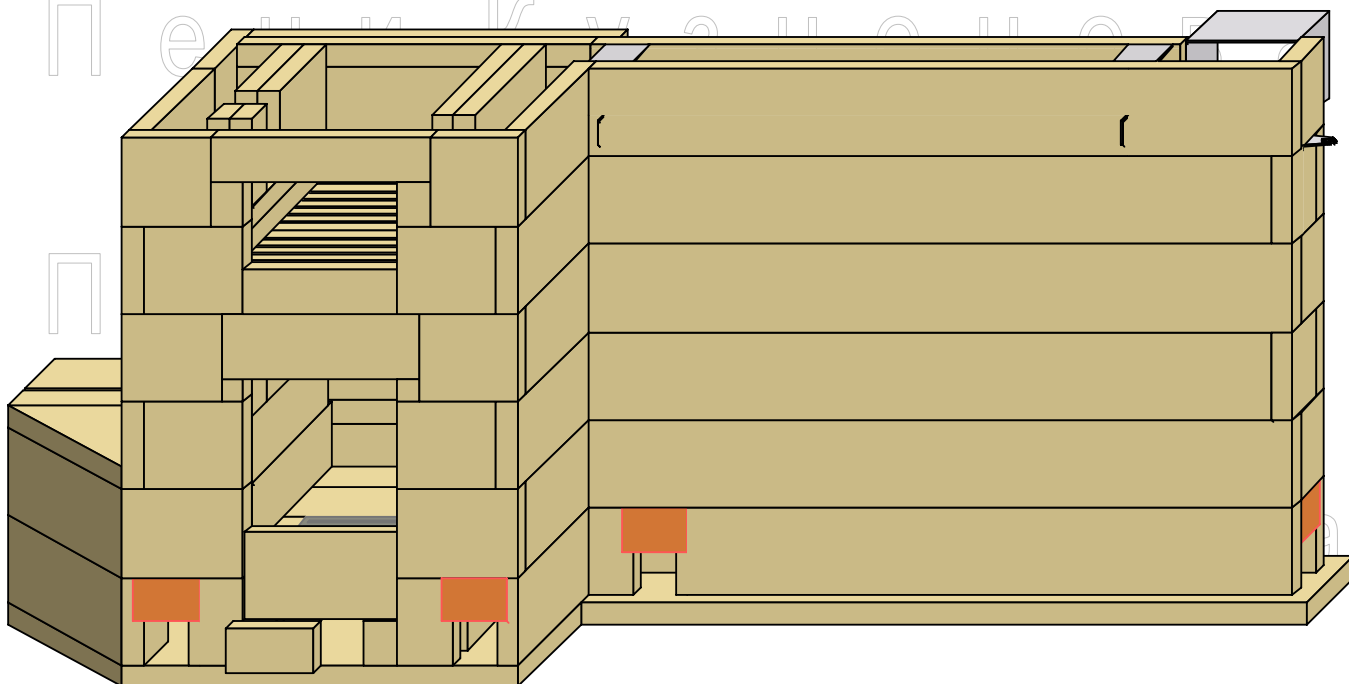
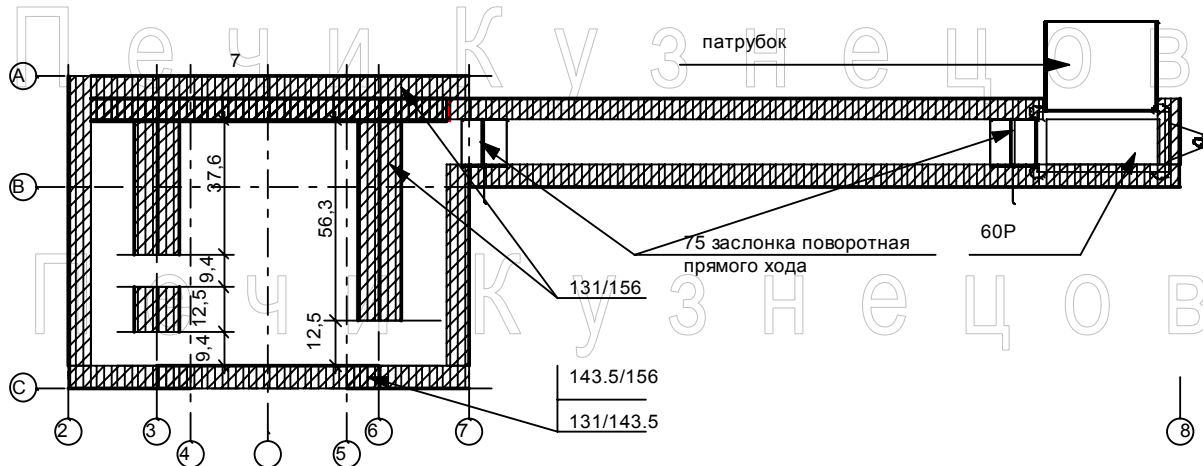
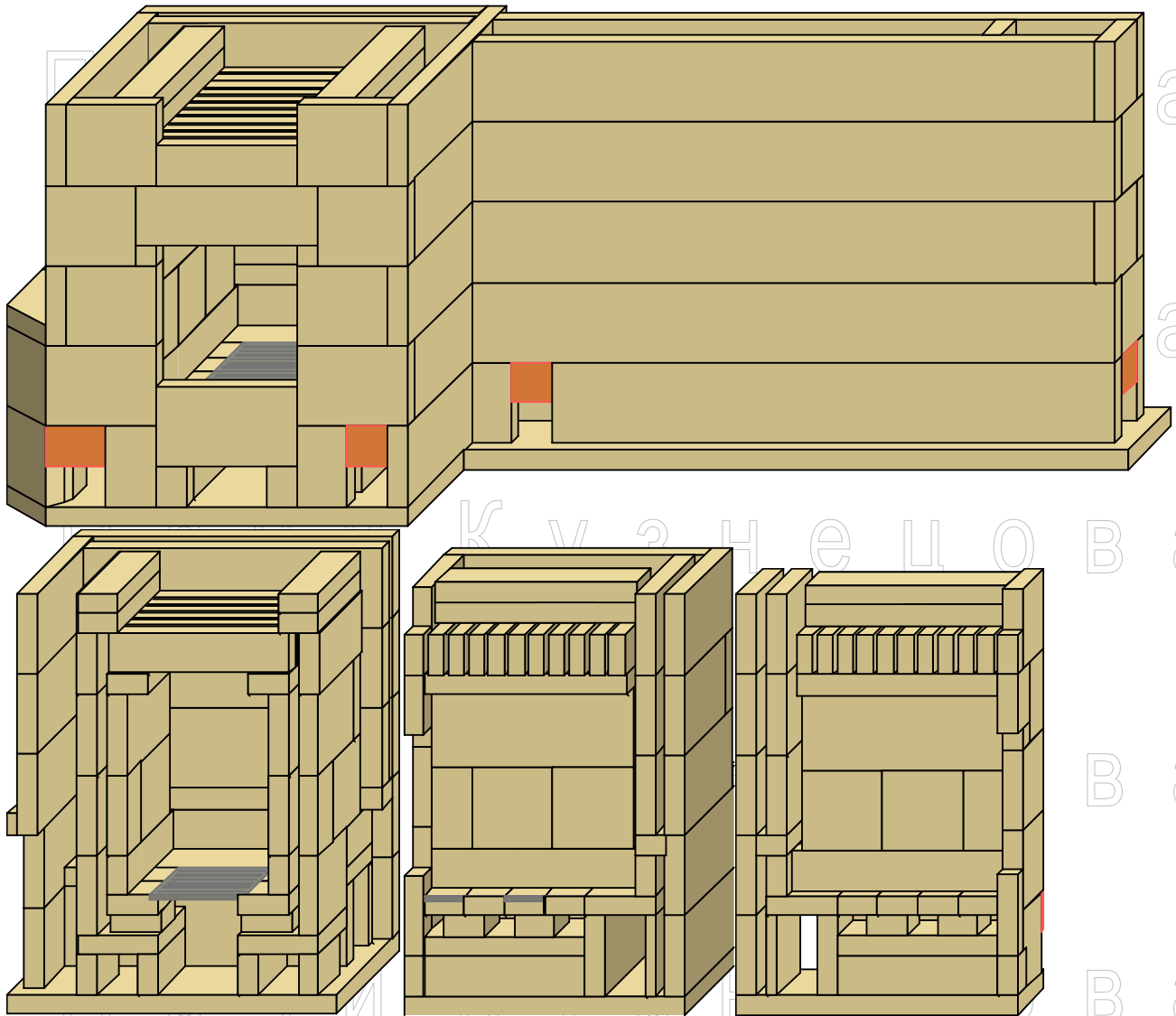
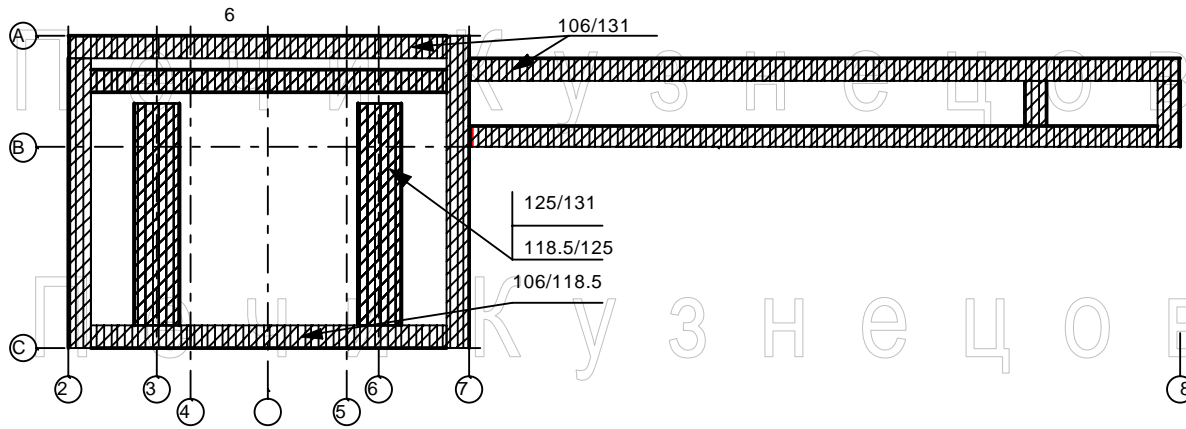

П е ч и К у з н е ц о в а

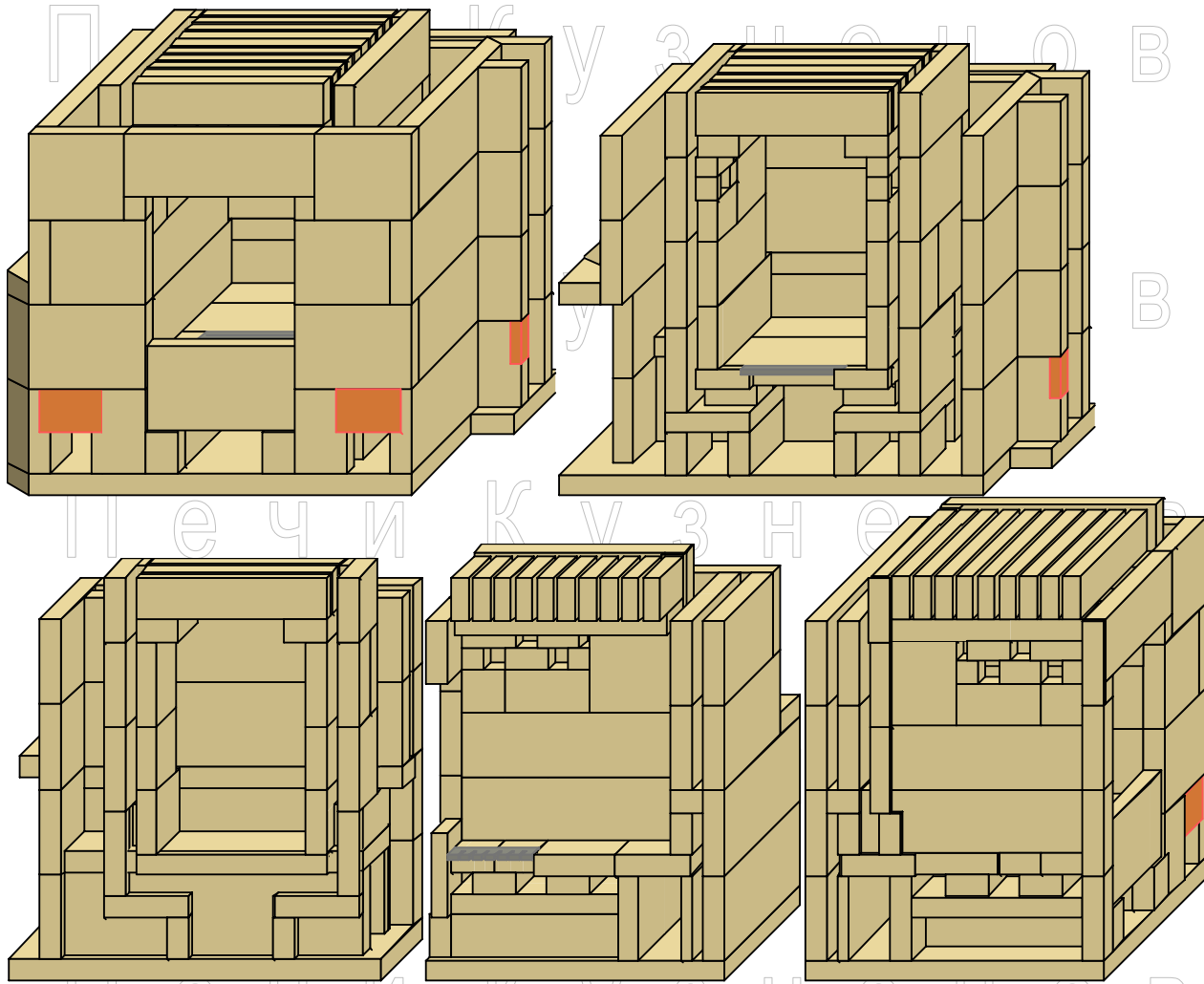
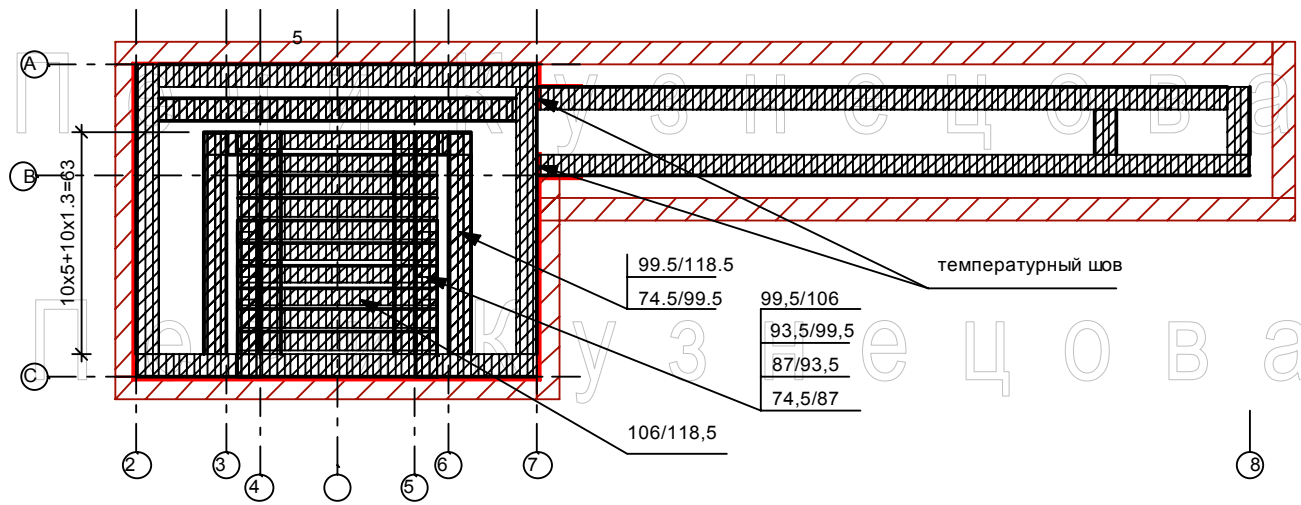

П е ч и К у з н е ц о в а

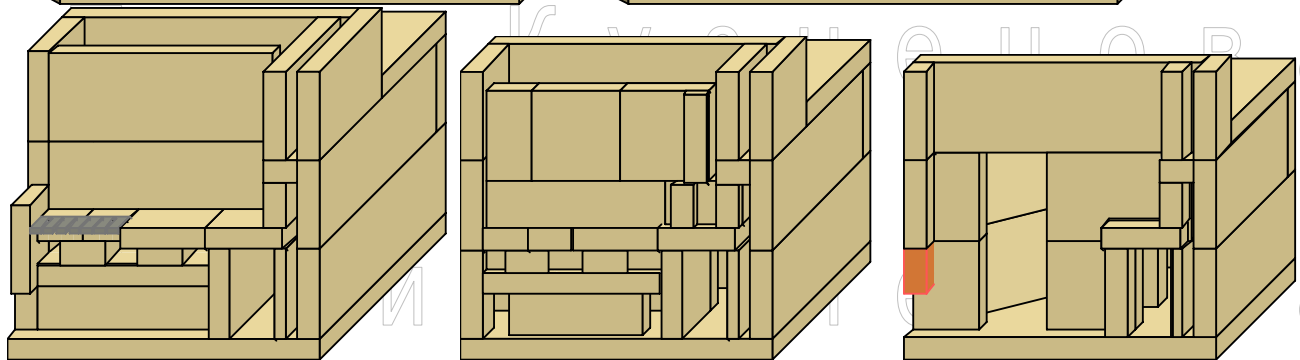
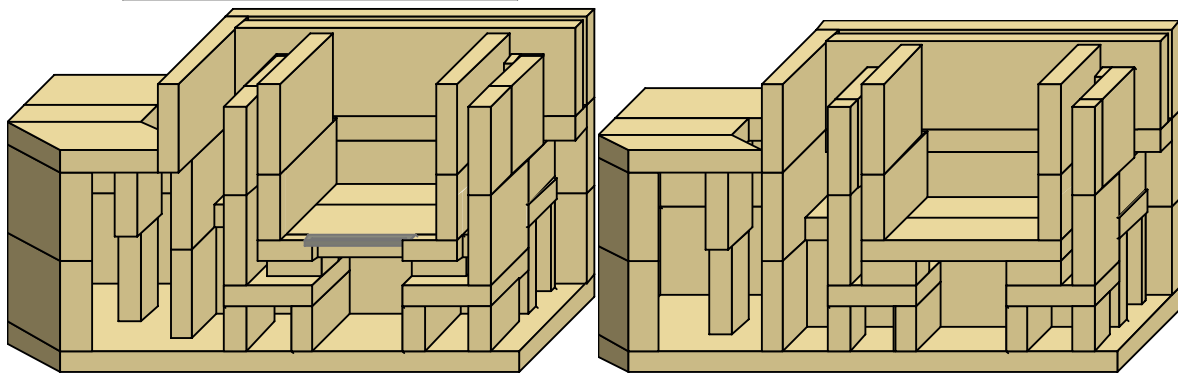
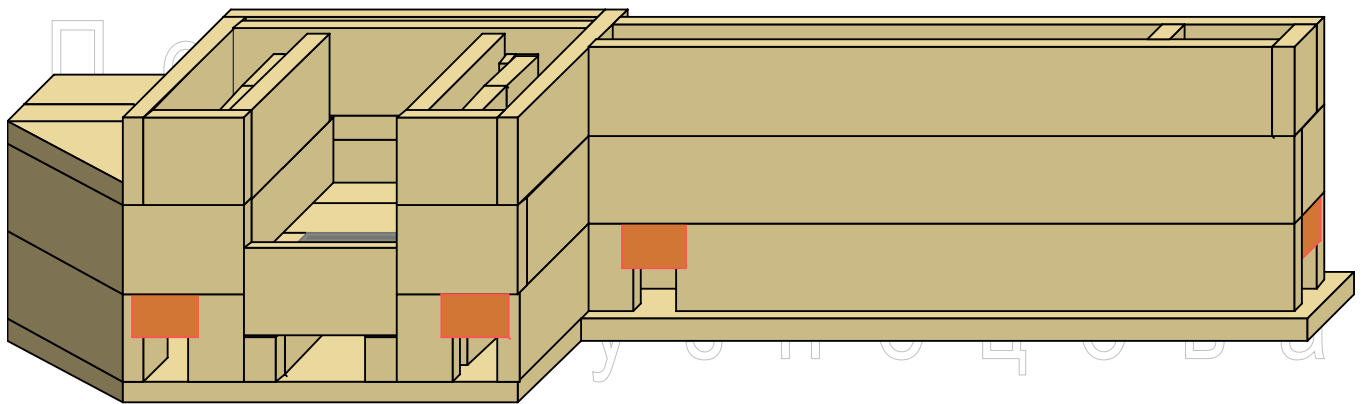
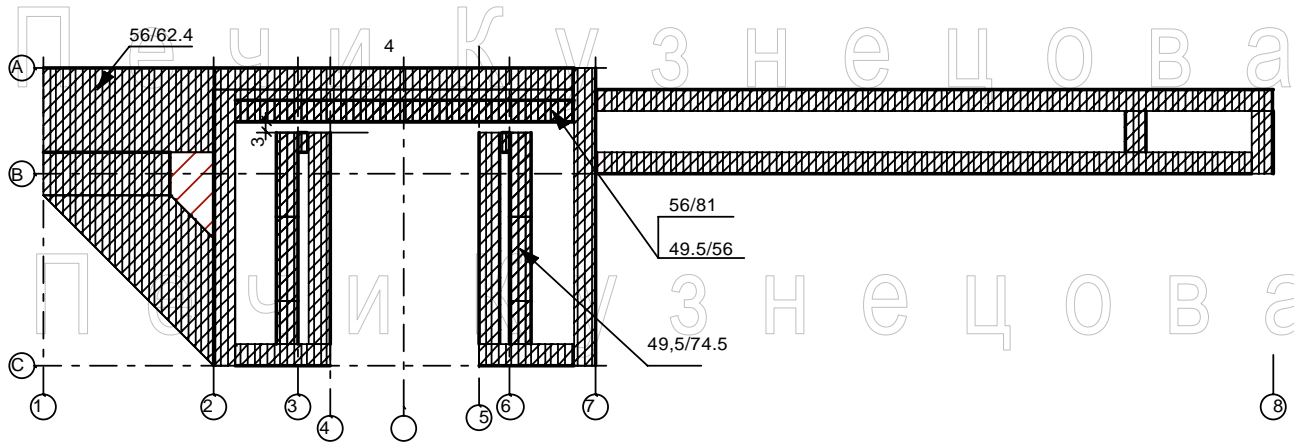

П е ч и К у з н е ц о в а

