

Masonry Heating on the Internet

MHA in Cyberspace

by Norbert Senf

MHA voting members will soon find their creations displayed on the Internet. The executive has agreed to fund an MHA site on the World Wide Web that will tentatively have the address <http://MHA-Net.org>. Net surfers will initially find an interactive homepage that will have links to a membership list, an archive of back issues of MHA News, as well as information about individual members.

Your editor will be the “webmaster” administering the site. Members are each requested to send one high quality color photo, which will be scanned in as a high resolution image that will be available online to any one of the estimated 30,000,000 computers that currently have Internet access. MHA-Net will be run from a high speed “server” (computer) in Atlanta with a fast direct connection to the fiberoptic backbone of the net, and browsers should encounter minimal delays in downloading information. It is hoped that images will be

storable at a high enough resolution to enable magazine publishers to get masonry heater images electronically for publication. No more waiting for your slides to be returned by magazine writers.

The MHA page will also provide links to members who have their own sites. These links are the essence of the Internet. By simply pointing to an item with a mouse and clicking the mouse button, you are taken almost instantaneously to whichever computer the information happens to reside on. It could be on the same machine, or on a machine on another continent. This feature is completely transparent to the user and is what has largely been responsible for the explosive growth of the “Web” in the last year.

Members who wish to set up their own sites will be able to rent server space through MHA-Net. A ten megabyte site will cost \$5/month, with no surcharges for high traffic.

(Continued on page 7)

In This Issue

MHA in Cyberspace	1
1996 Annual MHA Meeting	3
Report on 1995 MHA Annual Meeting	4
High Performance Masonry Heating	8
New Members	9
MHA Membership List	10
Integrated Wood Energy Systems for Sustainable Housing	13
Heating Water with Masonry Heaters	19
Washington State Fireplace Emissions Standard Under Way	23
Space Heating and Fireplaces: The View from CANMET'S Combustion Laboratory	24
Design and Operating Factors Which Affect Emissions from Residential Wood- Fired Heaters: Review and Update	32
The Hearth as an Element of the Sustainable House	51
Short Course on Masonry Heating Systems	61

**1996 Annual MHA Meeting
March 20 - 22, 1996**

**Government House Hotel &
Conference Centre**

Charlotte

North Carolina

(704)372-7550

Turn to page 3 for details



Volume 9 Number 1 Spring 1996

Published by:

The Masonry Heater Association of North America

Elected Officers: 94/95

President *Pat Manley*
Vice President *Ron Pihl*
Secretary *Christine Subasic, P.Eng.*
Treasurer *Lucille Frisch*

Business Office:

Administrator: Janet Peddycord, P. Eng.
The Masonry Heater Assoc. of N. America
11490 Commerce Park Drive
Reston, Virginia 22091

Telephone 703.620.3171
FAX 703.620.3928

Editorial Office:

Editor *Norbert Senf*
 c/o
Masonry Stove Builders
RR 5, Shawville
Québec J0X 2Y0
Telephone 819.647.5092
Fax 819.647.6082

Membership Policy:

Membership is open to anyone with an interest in masonry heating .

Annual membership dues:

Voting	200.00 (US)
Associate	100.00 (US)

IMPORTANT NOTE: Please check the membership list in the current issue and notify us immediately of any errors in your address, phone numbers, or dues status. Contact the Editor if the information published in this issue's membership list needs correction.

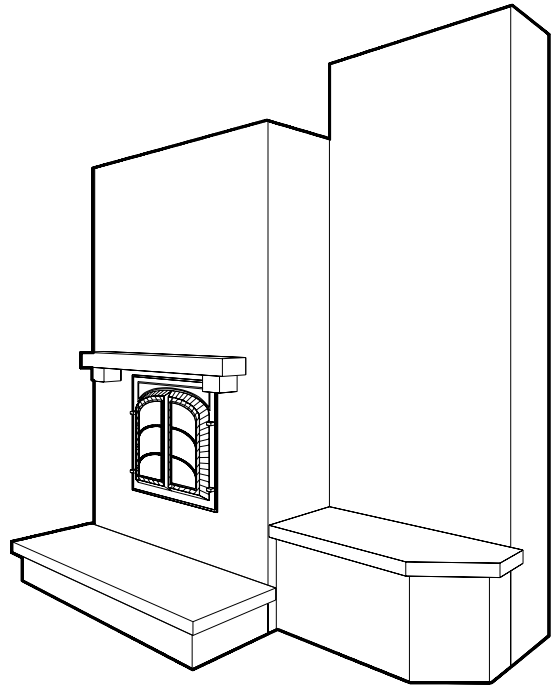

1996 Annual MHA Meeting, March 20 - 22, 1996

Government House Hotel & Conference Centre, Charlotte, North Carolina (704)372-7550

Tentative Agenda

Wednesday, March 20, 1996

6:00 pm - 8:00 pm **Welcoming Reception**

Thursday, March 21, 1996

8:00 am - 5:00 pm **MHA Annual Business Meeting**

8:00 am	Coffee & danish
8:30 am	Greetings and introductions
	Minutes and Treasurer's report
9:00 am	Elections
9:30 am	Administrator's report
	Newsletter
	Membership kit
	New brochure
	HPA booth (signup sheet)
	BIA report
11:30 am	Slide program development
	Skip Barnett video/slides
12:00 noon	Lunch (on your own)
1:00 pm	PR program update
	Marketing leads
1:30 pm	San Rafael testing report
	Lopez Labs testing update
2:30 pm	Education & training report
3:30 pm	1997 annual meeting
	time, location
4:00 pm	1996 budget
	Proposed testing
	Regulatory participation
	Pr/marketing
	Operating expenses
5:00 pm	Adjourn

Friday, March 22, 1996

8:30 am - 4:00 pm **MHA Annual Meeting**

8:30 am	Coffee & danish
9:00 am	The Internet
10:00 am	Initial certification written exam
11:00 am	ASTM standards discussion
12:30 pm	Lunch (on your own)
1:30 pm	MHA long term planning session
4:00 pm	Adjourn
7:00 pm	MHA banquet

Report on 1995 MHA Annual Meeting, March 23 - 25, Las Vegas, Nevada

This year's MHA meeting was a big success and well received by all who attended. In an effort to attract more working heater masons, the agenda included a full first day of wall-to-wall technical

Seppo Rajjas is chair of the Masonry Heater Caucus. Walter Moberg is chair of the Legislative committee.

Bakeoven Seminar with Allan Scott

Allan Scott is an Australian-born craftsman whose first trade was as a blacksmith. He is now a baker and a well-known designer and builder of woodfired brick bakeovens, both domestic and commercial. He makes his home in a rural setting north of San Francisco, where he practices the various aspects of his craft.

We had the opportunity to build one of Allan's ovens four years ago for a small commercial bakery outside of Ottawa. I was impressed with some of Allan's design

THE POILANE BAKERY IN PARIS IS WIDELY CONSIDERED TO BE AT THE PINNACLE OF THE BREAD BAKING ART. THEY USE A WOOD FIRED BRICK OVEN. THE OVEN IS HOT, RESULTING IN A SEARED, DARK CRUST. THE BAKERY HAS RECENTLY EXPANDED IN AN INTERESTING WAY. RATHER THAN BUILD LARGER OVENS, THEY HAVE REPLICATED THEIR EXISTING OVEN DESIGN 24 TIMES, WITH THE OVENS ARRANGED IN A LARGE CIRCLE. EACH BAKER HAS HIS OWN VILLAGE-SIZE OVEN - ABOUT 12 - 14 FEET SQUARE.

sessions. Accordingly, we'll start this report with a technical session that is certain to be of great interest to all members unable to attend, and then cover the business part of the meeting.

MHA Business Meeting (Minutes)

MHA's annual business meeting was held at 8 am on Friday, March 24, 1995 at the Las Vegas Convention Centre.

The minutes from the 1994 meeting were published in the newsletter and were accepted. Lucille Frisch presented a Treasurer's Report. The current bank balance was 15,430.90.

Tina Subasic presented a report on activities at BIA. The Tech Notes on masonry heaters have not been revised yet, but they will be redone. There is an effort to produce a Sustainable Products Guide. Also, there was a proposal to incorporate changes into NFPA 211 (National Fire Code) to include masonry heaters, but these were turned down. David Johnston, NFPA member, proposed setting up a small committee to meet in the fall and see some masonry heaters.

The ASTM Standard Guide for Solid Fuel Burning Masonry Heaters passed in February, and is known as E1602.

Charlie Page attended the meeting to give a report on marketing efforts that he has been retained for by MHA, through John Lagamba.

The 1996 MHA meeting will be in Charlotte, NC. Dates are not finalized yet, but will likely be immediately prior to and during the HPA show, which runs from March 22-25.

innovations that resulted in a low cost, easy to build oven. After three years of commercial use, the owners report that they are very happy with the oven's performance and in fact are planning to expand and build two more. Fuel cost per loaf of bread is two cents. Allan started his presentation by describing some of the features of his retained heat design:

The largest size oven has 6 foot by 8 foot hearth area. The vaulted baking chamber ceiling consists of 4.5 inches of firebrick capped by 2 inches of reinforced concrete (thus cleverly eliminating the need for traditional structural steel to take up the vault side thrust.)

The ratio of door height to dome height is 63%. The oven is filled with wood, and a fairly slow fire results in a very evenly heated oven. Smoke exhausts at the top of the door where it goes into a collection hood. The dome is kept as low as possible, which provides the maximum amount of steam. For breads, a 15" high dome with a 10" door is close to ideal, while an 18" dome with a 12" door is more versatile for restaurants.

Techniques for bigger ovens

For larger ovens, more support for the arch needs to be provided during construction. This can be done by pouring the concrete supports for the sidewalls first. For restaurants, calcium aluminate concrete is used. The thickness of the arch is increased if more batches per firing are needed. A 6" arch will give 8 batches, while the standard arch gives 4 batches - more for lighter bread.

Heavy breads require a hotter oven. This requires a more tricky firing technique, and this is one drawback for this oven style.

Hearths should be smooth, with bricks laid up on edge, dry, onto a sand bed. Soapstone is too conductive and results in too hot a hearth. Castable refractory hearths have peeling problems.

Allan's philosophy, and advice to oven builders, is to keep it simple. This is exemplified in the traditional Québec oven which, however, is not as efficient. The starting point for oven building should be the bread. Allan advocates a switch to a more appropriately scaled economy and lifestyle, and his oven designs and his bread reflect this.

Pizza ovens

Pizza ovens use a continuous fire in the oven during the baking. This automatically results in the required high air temperature (700F). This same style of oven is used for middle eastern food such as pita, matzoh, etc. Bagels are also done this way. Using this type of oven is labor intensive and requires a lot of skill. Storage capacity is not really required in this type of oven, and castable refractory is an appropriate material. A small prefabricated Italian oven starts at about \$6000, but a homebuilt version can be built for around \$150.

The breadbaking revival

The Poilane bakery in Paris is widely considered to be at the pinnacle of the bread baking art. They use a wood fired brick oven. The oven is hot, resulting in a seared, dark crust. The bakery has recently expanded in an interesting way. Rather than build larger ovens, they have replicated their existing oven design 24 times, with the ovens arranged in a large circle. Each baker has his own village-size oven - about 12 - 14 feet square. An article on Poilane can be found in the Jan/Feb issue of Smithsonian magazine.

Another article about Poilane included a photograph of the owner in the local forest, inspecting his firewood supply. Alan feels that this is a right use of wood, and stimulates the forests. (French forestry practices have been enlightened for a long time. France has about 1/7 th the forest area of Canada, but produces a higher dollar volume of forest products. 200 year crop rotations are not unheard of.)

One thing that is apparent on the West Coast is that a bread revival is under way. Two good recent books on the subject are The Village Baker by Joe Ortiz and Bread Alone by Daniel Leader and Judith Blahnik. Allan handed out a list of ovens that he had built, and we had the opportunity to visit two of them on our drive from Las Vegas to Vancouver. We also visited several other notable bakeries - Acme in Berkeley and Gail's in Capitola. Jerry Haupt arranged a visit during a burn for Patrick Manley and myself to the Black Diamond Bakery

in Black Diamond, WA. They have a woodfired bakeoven with a 10' x 12' hearth that has been in continuous use since 1902. Wood consumption on this oven is quite high at 0.5 cords per day. My guess is that this could be cut by 75% using modern materials and techniques.

Ideal firing technique

Alan finished his presentation with a discussion of firing techniques:

- Any type of wood is suitable, and it is a nice niche for limb wood, around 2" in diameter.
- Long lengths can be used, around 4 to 6 feet.
- Diameter should be larger for softwood
- Larger diameter wood results in more of the heat going into the hearth, and vice versa.
- A kindling fire is built in the mouth of the oven, and the fire is allowed to burn slowly to the back. The fire can be encouraged by raking the coals.
- If you reload, then you cut off the air supply to the first load. You have to wait for the first load to burn before adding wood.
- The front of the oven will be a little cool because of the air supply. Coals are raked to the front as the last thing.
- A damp mop is used to remove the ash from the hearth.
- Allan uses a wooden door plug cooled with a damp terrycloth. The bread is done when the towel starts to burn.
- The widest door for a 48" oven is 24". Usually the door is 19", to fit a standard 18" pan. There can be problems with doors that are too wide, ie., if automatic loading equipment is used.
- Firing times for a 4 x 6 oven are approximately as follows: from a cold start - 3.5 to 4 hours; a warm oven - 2 to 2.5 hours; third and subsequent days - 1.5 to 2 hrs.
- Preheat the oven the night before - it doesn't take much more wood.

Additional tips: A good rhythm is to bake 2 days per week.

At the Cafe Beaujolais in Mendocino, the oven is usually 425F in the morning. They prestack and bake the wood. Good sourdough bread will last for several weeks. The fermentation that the yeast undergoes in sourdough bread is important - it adds nutrition, and makes the bread more digestible. The challenge is not to make the bread too sour.

For rye bread, a cool oven is used, around 300 degrees. Steam the bread while baking, and then leave it for 24 hours.

Afternoon Technical Session:

Dale Hisler

After Alan's presentation, longtime heater mason and baker Dale Hisler shared some additional tips with us.

- Dale recommends the installation of an ashdrop at the back of the oven.
- One way to gauge oven temperature is to sprinkle some flour onto the floor of the oven.
- Dampers are an important element for regulating oven temperatures.
- For sourdough, a starter can often be made from existing sourdough bread.
- Steam can be added by installing copper tubes to trickle water onto the oven floor.
- Large ovens tend to have complex damper systems, and a personality.

Albie Barden

Albie Barden led a keenly awaited technical session on the subject of refractory failures. He started the discussion by expressing some of his own concerns over the years. Castable firebox lintels have been known to occasionally fail, leading to what he terms callback trauma. Thermal shock is the main durability concern that stovebuilders have to deal with, and traditionally stoves were rebuilt every 20 or 30 or 50 years. He discussed one manufacturer's learning curve, which has resulted in the use of smaller elements. He has addressed his own concerns with weak areas of the firebox by developing a patented, replaceable precast throat system. Key design strategies should be access and replaceability.

Dale Hisler commented that he has seen a change in the quality of refractory materials over the years, and that he has recently started to see quality problems with firebricks.

A lively discussion followed, and was appreciated by all.

Norbert Senf

The technical session wrapped up with a presentation by your editor. With the help of overhead slides, we looked at several current projects at Masonry Stove Builders. Included was a detailed account of the design of the 15 kW heater at the Kitchener-Waterloo (Ont) YMCA Earth Residence. I also gave a preview of my 1995 Air and Waste Management Association paper, which appeared in early draft form in the previous issue of MHA News.

Attendees at 1995 MHA Meeting

Name	Company	Voting
Tina Subasic	BIA	Yes
Larry Lamont	Halifax Bricklayers' Coop	Yes
Gene Hedin	Masonry Stove Builder	Yes
Dale Hisler	Lightning Arrow Stove Works	Yes
Tom Stroud	DWS	Yes
Jerry Frisch	Lopez Quarries	Yes
Lucille Frisch	Lopez Quarries	Yes
Albie Barden	Maine Wood Heat	
Tim Custer	TNT Masonry Heaters	Yes
Fred Salazar	Inverness Masonry Heat	Yes
Rod Zander	The Artisan's Workshop	
Jim Donaldson	European Masonry Heaters	
Gary Hart	Aaron's LTD Chimney Service	
Ron Pihl	Cornerstone Masonry	Yes
John Lagamba	Temp-Cast	Yes
Norbert Senf	Masonry Stove Builders	Yes
Carol Manley	Brick Stove Works	
Pat Manley	Brick Stove Works	Yes
Jerry Haupt	Kent Valley Masonry	Yes
Erik Nilsen	Thermal Mass Inc.	Yes
Marcus Flynn	Pyro Masse	
Doug Fry	Fry Masonry Construction	Yes
Heinz Flurer	Biofire Inc.	Yes
Walter Moberg	Firespaces/WM Design	Yes
Paul Hendricksen	Firespaces/WM Design	

MHA on the Internet

(Continued from page 1)

As an example, this newsletter in its final typeset form including graphics is about 1.7 Megabytes of data. Storing it online, ie. available by phone 24 hrs/day, would therefore cost about \$0.85 per month. This means that even very small businesses can afford to have catalogs, product information, etc., easily available to a global audience. It would cost less to store this issue of the MHA News online, for example, than sending a single copy by mail. It is hoped that members will be encouraged to take advantage of the increasingly easier and cheaper access that is available today. My access from Shawville through a "service provider" in Ottawa, for example, costs \$25/month for 50 hours of usage, or about 0.50/hr. One of the main benefits since signing up last summer has been e-mail, for which there is no charge. E-mail only service can be had for as little as \$5.00 per month.

We met Charlie Page (Jumpstart Marketing) in Burlington, Vermont at Solid Fuel Expo 96. Charlie is known to many MHA members as the former CEO of Thermal Energy Storage Systems, and as an expert in marketing hearth industry products. Charlie stated that he has been involved recently in developing a site on the Internet known as HearthNet, together with New Jersey stove retailer Craig Issod. For those of you who already have Internet access, it can be found at

http://hearth.com. It is the electronic equivalent of a hearth products mall, where you can not only shop among many dealers, but also among many sources of information. This site receives a lot of traffic, and has received the distinctive logo that is reserved for the top 5% of Internet sites. Charlie states that Stoveworks, Issod's company, has done over \$25,000 in business through the Internet since the site was started a few months ago.

In Charlie's opinion, masonry heaters are tailor made for the Internet - they are a specialty product with a high level of information demand from customers. The concept of "narrowcasting" on the Internet as opposed to broadcasting through the mass media means that, although the Internet is overloaded with information, it is **very** easy for customers to find something specific if it is on the net. This is made possible through the use of powerful "search engines" that are available for use online for free. For example, in writing this article, I needed to find the address for HearthNet. Here's what I did:

- clicked on a small picture (icon) of a telephone on my computer screen - this caused my computer to telephone my service provider and automatically log me on to the Internet.

- clicked on a small icon for Netscape, the "browser" program that gives me an easy to use graphical interface to the Worldwide Web.

- clicked on a button labelled "search"

- typed in "hearth net". This caused search engine software running on extremely fast computers provided free of charge by Digital Equipment Company (DEC) to search a 9 billion word index of online information. It came back with about 1000 hits in less than 5 seconds. The hits were arranged in order of how closely they matched my key words. I had to scroll through about 30 items (and resist the temptation to explore the more interesting sounding ones) before I found what I was looking for.

- clicked on the item, which took me directly to the HearthNet home page (I'd never been there) in about 5 seconds.

Total time for this whole operation was under 5 minutes. If I were someone building a custom low energy house looking for suitable heating equipment, this is how long it would take me to find HearthNet, which will probably become a gateway to all of the online woodheating resources. It would be a very easy way to bring traffic to an MHA site, for example. Charlie will be at the Charlotte meeting, and I have invited him to the MHA meeting to give us more details on what is involved.

As you may have guessed, Masonry Stove Builders will soon have a link on MHA-Net. It is hoped that other manufacturers will follow suit, as well as individual builders. They can either do it on MHA-Net, or contract with a third party - the actual location of the computers storing their information (and making it available online 24 hrs a day) is transparent to the user. The current buzzword is "content" - it's in short supply, despite all the glitz and hype. High quality information will be the new currency on the Internet.

Many users first get online through one of the large commercial services such as America Online (AOL) or Compuserve. There are several groups of chimney sweeps online trading technical information, and AOL seems to be the most popular source for access. Free software diskettes that automate the process can be found attached to several of the computer magazines found at newstands. If you don't have a modem yet, you can go to a large discounter such as Price Club/Costco and buy a complete package such as "Internet in a Box" for under \$100 that includes free online time.

High Performance Masonry Heating

Stephen Bushway

Deer Hill Masonry Heat
224 West Street
Cummington, MA 01026-9643
413.458.9660

(This information is based on emission test results done with a Finnish contraflow heater design with a grate and air supply from under and in front of the grate)

Whether you're a seasoned masonry heater owner or are reading this as a new owner, there are some newly discovered firing techniques you will want to employ to get the most out of your hearth.

- Use regular cordwood! Yes, it is not necessary to burn sticks 2" to 3" across to get the rapid, complete combustion that masonry heaters are noted for. Actually, 4" to 6" pieces such that 9 to 12 pieces will fill your firebox when cross hatched will provide better air/fuel ratio for complete, and more usable combustion. The bigger pieces allow more time for the masonry mass to soak up the fire's heat - yielding better heat transfer to your home.
- Place smaller wood, kindling and paper on top of this load and light from the top! The revolutionary top burn greatly reduces emissions during the dirtiest part of a firing - the first 10 minutes or so. Lighting the load from the top of the pile yields a candle-like burn, allowing the firebox to heat up as the volatile gases are being more evenly released.
- Take a little extra care in laying up your fire. A good "fuel load configuration" is well balanced and won't topple over prematurely. Allow a 1" airspace between pieces, placing the largest pieces first and the bottom row running "front to back" in the firebox.
- Don't admit air from below the grate until the fire is down to coals. Use the air slots in the door, if provided. If not, cut scrap dimensional lumber so that a piece will cover the grate and air is admitted from the front. With a top burn fire the piece will block grate air until it is burned through - well into the firing. Alternately, you can adapt your doors so that they will 3/4 inch of air between them but can not be accidentally be opened further. This modification was lab tested for emissions with excellent results. During the coal burning phase,

rake the coals so they evenly cover the grate with air coming from below.

- It is more efficient to have one full firing than 2 fires half as large.

If you've been burning small pieces kindled at the bottom in your contraflow heater, chances are there is soot in the heat exchange channels. This can effectively be cleaned from the cleanout door using a rod and brush designed for cleaning pellet stove chimneys. This will better allow them to absorb heat from future fires.

Burning cordwood has so many benefits, economy-wise. And as you're probably aware, masonry heaters provide the cleanest burning solid fuel appliances available. Now, following these simple practices you can be assured that you are providing yourself and your loved ones simple, yet state-of-the-art heat more cleanly than ever.

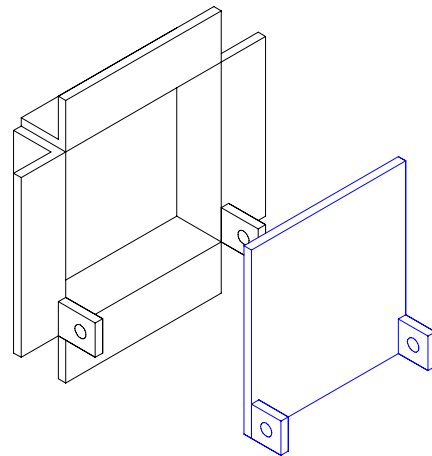

Figure 1. Bypass damper

New Members

Voting

Paul Belden IV

Belden Brick and Supply Co.
620 Leonard St. N.W.
Grand Rapids, MI 49504
616.459.8367 FAX 459 8421

Richard Larsen

D. Larsen Masonry Construction
10801 Jackpine Rd. NW
Bemidji, MN 56601
218.751.0523

John Pilger, President

NY State Chimney Sweep Guild
136 Floyd St
Brentwood NY 11717
516.273.1180 800.249.3943

Larry Lamont

Halifax Bricklayer's Co-operative
2033 Maynard Stree
Halifax NS B3K 3T1
902.422.9444 fax 425.0408

Gary Hart

Aaron's Ltd. Chimney Services, Inc.
2850 Riverbend Acres
Eureka MO 63025
314.938.4318

Ben Hurd

Missouri Stove & Chimney
P.O. Box 307
Sparta MO 65753
417.278.3320

Eugene Hedin

Gene Hedin Masonry Builders
5907 Old Miller Trunk Hwy.
Duluth MN 55811
218.729.9096

Associate

Carl Oehme

Keystone Masonry
607 Manitoba Ave.
Winnipeg MN R2W 2H1

Steve Cohan

Hot Rock Masonry
Box 526
East Sound WA 98245

Paul Mason

Mason's Masonry Supply
6291 Netherhart Road
Mississauga ON L5T 1A2

Mary Feeney, Administrative Assistant
Northeast Sustainable Energy Association
50 Miles Street
Greenfield MA 01301

Walt Pearce

W.E. Pearce Inc.
4161 Kiehl Rd.
Friday Harbour WA 98250

Walter Obergfell

Blackforest Construction Ltd.
C-35 RR 1 McMillan Road
Lone Butte BC V0K 1X0

Sam Foote, P. Eng. (ret.)

Suite 210, 170 Yonge St. S.
Aurora ON L4G 6H7

Reciprocal

B.J. McCallum

Real Goods Trading Company
286 Wilson St.
Amherst WI 54406

Architects, Designers and Planners for Social Responsibility

P.O. Box 9126
Berkeley CA 94709-0126

Steve Chappell, editor

Joiners' Quarterly
P.O. Box 249, Snowville Rd.
West Brownfield ME 04010

Sal Alfano, editor

Journal of Light Construction
RR 2, Box 146
Richmond VT 05477

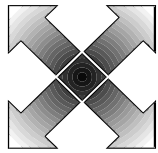

**Masonry
Heater
Association
Of North America**

MHA News

Volume 9 Number 1

Spring 1996

MHA Membership List

Voting Members

Name	Company	Address	Town	State/Zip	Tel(B)	Tel FAX	Dues
Albie Barden	Maine Wood Heat Co.	RFD 1, Box 640	Norridgewock	ME 04957	207.696.442	696.5856	95
David (Buck) Beckett	Thermal Mass Fireplaces	P.O. Box 1562	Jackson Hole	WY 83001	733.4029		95
Paul Belden IV	Belden Brick and Supply Co.	620 Leonard St. N.W.	Grand Rapids	MI 49504	616.459.8367	459.8421	96
Steve Bushway	Deer Hill Masonry Heat	224 West St.	Cumington	MA 01026	413.634.5792	634.5037	94
Gabriel Callender	Foyer Radiant DeBriel	C.P. 220	St-Eduard-de-Frampton	PQ G0R 1M0	418.387.8961	386.3600	95
Rick Crooks	Mutual Materials Co.	PO Box 2009, 605 - 119th Ave. NE	Bellevue	WA 98009	206.603.0540	603.0538	95
Timothy Custer	Top Hat Chimney Sweeps	12380 Tinkers Creek Rd.	Cleveland	OH 44125	216.524.5431		95
A. Michael D'Arcangelo	Kachelofen Unlimited	1407 Caves Camp Road	Williams	OR 97544	503.846.6196		96
Bill Derrick	Alternate Energy Systems	Box 344	Peru	NY 12972	518.643.9374	643.2012	95
Jerry Frisch	Lopez Quarries	111 Barbara Lane	Everett	WA 98203	206.353.8963	742.3361	96
Doug Fry	Fry Masonry Construction	66605 N. Lakeview	Sturgis	MI 49091	616.651.9289	same	96
George Gough	Gough Masonry Ltd.	834 Old Garden River Road	Sault Ste. Marie	ON P6A 6JA	705.253.4314	945.1480	95
Douglas Hargrave	Inverness Masonry Heat	1434 Dairy Rd.	Charlottesville	VA 22903	804.979.7300/800.373.6352	979.6416	95
Gary Hart	Aaron's Ltd. Chimney Services, Inc.	2850 Riverbend Acres	Eureka	MO 63025	314.938.4318		95
Jerry Haupt	Kent Valley Masonry	23631 S.E. 216th St.	Maple Valley	WA 98038	206.432.0134	413.1771	95
Eugene Hedin	Gene Hedin Masonry Builders	5907 Old Miller Trunk Hwy.	Duluth	MN 55811	218.729.9096		96
Dale Hisler	Lightning Arrow Stove Works	Box 25	Pray	MT 59065	406.333.4383		94
Stan Homola	Mastercraft Masonry	P.O. Box 73	Brush Prairie	WA 98606	206.892.4381	same	95
Ben Hurd	Missouri Stove & Chimney	P.O. Box 307	Sparta	MO 65753	417.278.3320		95
Ken Johnston	Johnston Masonry	1529 Wildwood Road	Duluth	MN 55808	218.525.7278		94
John LaGamba	Temp-Cast Enviroheat Ltd.	33320 Yonge St. P.O. Box 94059	Toronto	ON M4M 3R1	416.322.6084	486.3624	96
Larry Lamont	Halifax Bricklayers' Co-Operative	2033 Maynard St.	Halifax	NS B3K 3T1	902.422.9444	423.6115	96
Richard Larsen	D. Larsen Masonry Construction	10801 Jackpine Rd. NW	Bemidji	MN 56601	218.751.0523		96
David Lyle	Heating Research Co.	Box 300	Acworth	NH 03601	603.835.6109		95
Mark McKusick	Hearth Warmers	RR 1 Box 27	Colrain	MA 01340-9705	413.624.3363	624.3367	96
J. Patrick Manley	Brick Stove Works	374 Nelson Ridge Rd.	Washington	ME 04574	207.845.2440	same	95
David R. Moore	MTC Construction	11817 Vail Rd. S.E.	Yelm	WA 98597	360.458.4866		95
Erik Nilsen	Thermal Mass Inc.	RR 1 Box 367	Littleton	NH 03561	603.444.6474		96
Brian/Marcia Olenych	Olenych Masonry Inc.	HC 65 Box 3	Bovina Centre	NY 13740	607.832.4373	832.4561	95
Jamie Paiken	Jamie Paiken Masonry	600 Cove Rd.	Ashland	OR 97520	503.482.4379	same	95
Steve Patzer	Patzer & Co. Masonry	3N 743 RTE 31	St. Charles	IL 60174	708.584.1081		95
Walter Pearce	W.E. Pearce Inc.	4161 Kiehl Rd.	Friday Harbor	WA 98250	360.378.2094		95
Janet Peddycord	Brick Institute of America	11490 Commerce Park Drive	Reston	VA 22091	703.620.3171	620.3928	95

Ron Pihl	Cornerstone Masonry	Box 83	Pray	MT 59065	406.333.4383		95
Dan Pike / Al Frakes	Old World Masonry Heat	196 Quaker Highland Rd.	Peru	NY 12972	518.643.0463		95
John Pilger, President	NY State Chimney Sweep Guild	136 Floyd St	Brentwood	NY 11717	516.273.1180	same	95
Frank Pusatere	Colonial Associates Inc.	48 Radnor Ave.	Croton on Hudson	NY 10520	914.271.6078		94
Seppo Raijas	Tulikivi U.S. Inc.	255 Ridge-McIntire Rd.	Charlottesville	VA 22902	804.977.5500	977.5164	96
Keith Roosa	Hickory Mountain Chimney Sweep	P.O. Box Q	Wallkill	NY 12589	914.895.2750		95
Stanley Sackett	Sackett Brick Co.	1303 Fulford Street	Kalamazoo	MI 49001	616.381.4757	381.2684	96
Fred Schukal	Sleepy Hollow Chimney Supply	85 Emjay Blvd.	Brentwood	NY 11717	516.231.2333	231.2364	96
Norbert Senf	Masonry Stove Builders	RR 5	Shawville	PQ J0X 2Y0	819.647.5092	647.6082	96
Ben Sotero	Sotero Masonry and Construction	PO Box 804	Aptos	CA 95001	408.688.0509	684.1327	96
Tom Stroud	Dietmeyer Ward & Stroud	P.O. Box 323	Vashon	WA 98070	206.463.3722	463.6335	95
Tom Trout	Vesta Masonry Stove Inc.	373 Old Seven Mile Ridge Rd.	Burnsville	NC 28714	704.675.5247	675-5666	95
Don & Gary Wilkening	Wilkening Fireplace Co.	HCR 73 Box 625	Walker	MN 56484	218.547.1988	547-3393	96
					/800.367.7976	/800 591 5884+G4	
Rod Zander	Artisan's Workshop	127 North Street	Goshen	CT 06756	203.491.3091	same	96

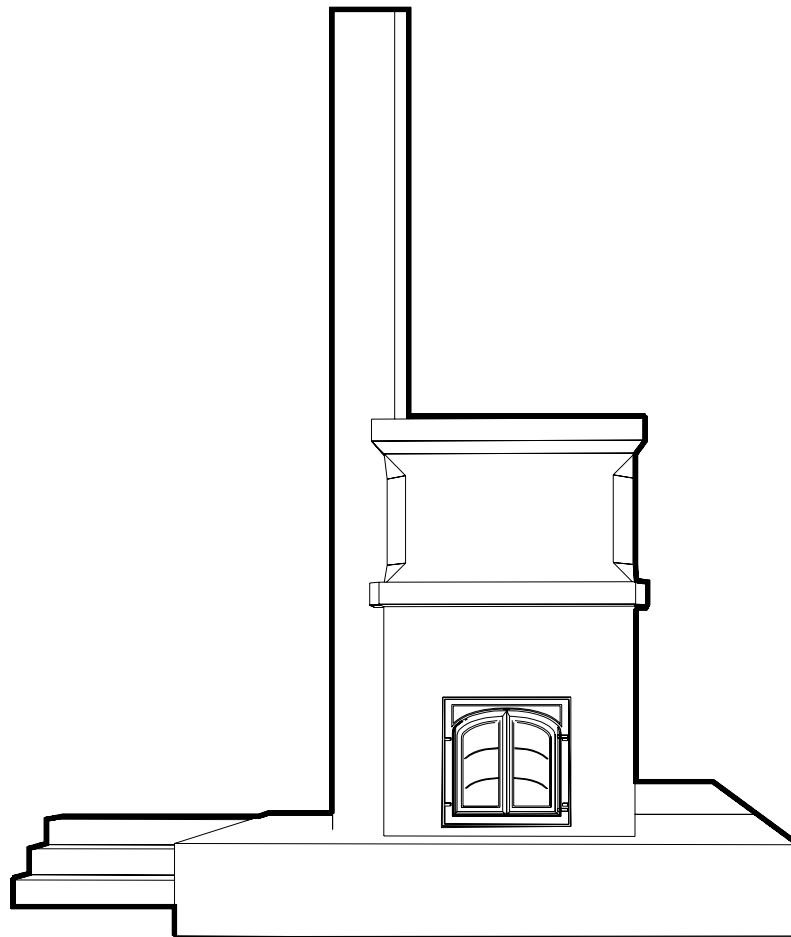

Associate Members

Name	Company	Address	Town	State/Zip	Tel(B)	Tel(FAX)	Dues
Bill Kjorlien	BIA Region 9	5885 Glenridge Dr. #200	Atlanta	GA 30328	404.255.7160	843.3278	95
Bob Gossett	BoB Gossett Masonry Design	8204 Midvale Rd.	Yakima	WA 98908	509.966.9683		95
Carl Oehme	Keystone Masonry	607 Manitoba Ave.	Winnipeg	MN R2W 2H1	204.586.1726	same	95
Dr. Ernst Rath	Aug. Rath jun AG	Walfischgasse 14	A-1010 Wien	Austria	43.1.513.44.26.0	43.1.51.89.17	95
Larry James	High Country Stoves	415 S. 5th. St.	Laramie	WY 82070	307.745.4488	745.4488	95
Marcus Flynn	Pyro Mass	4390 Coloniale	Montreal	QC H2W 2C6	514.844.9824	514.843.5331	96
Masonry Department	Greater Lowell Reg. Voc-Tech School	230 Pawtucket Blvd.	Tyngsboro	MA 01879-2199	508.454.3453		95
Peter Solac	Woodland Way, Inc	1203 Washington Ave. So.	Minneapolis	MN 55415	612.338.6606	339.3391	95
Richard Ellison	Master Builder Design and Construction	3626 Commonwealth Ave.	Charlotte	NC 28205	704.347.1380		95?
Robert Herderhorst		6910 Navaho Trail N.E.	Bremerton	WA 98310-9408	206.396.1001		
Steve Cohan	Hot Rock Masonry	PO Box 526, Rt. 1, Box 85-S	Eastsound	WA 96245	206.376.5505	376.5552	96
Steve Cohan	Hot Rock Masonry	Box 526	East Sound	WA 98245	360.376.5505		95
Walter Obergfell	Black Forest Construction Ltd.	C-35 RR 1 McMillian Road	Lone Butte	BC V0K 1X0	604.395.2197	395.4578	95
Sam Foote	Suite 210	170 Yonge St. S.	Aurora	ON L4G 6H7	905.727.6950		96
Paul Mason	Mason's Masonry Supply	6291 Netherhart Road	Mississauga	ON L5T 1A2			95

Reciprocal Members

Sal Alfano, editor	Journal of Light Construction	RR 2, Box 146	Richmond	VT 05477	800.375.5981	802.434.4467	reciprocal
Architects, Designers and Planners for Social Responsibility		P.O. Box 9126	Berkeley	CA 94709-0126			reciprocal
Steve Chappell	Joiners' Quarterly	P.O. Box 249, Snowville Rd.	West Brownfield	ME 04010	207.935.3720		reciprocal
Mary Feeney	Northeast Sustainable Energy Association	50 Miles Street	Greenfield	MA 01301	413.774.6051	774.6053	reciprocal
Jay Hensley	SNEWS	P.O.Box 98	Wilmore	KY 40390	606.858.4043	same, call first	reciprocal
Ken Hooker	Masonry Construction Magazine	426 S. Westgate	Addison	IL 60101			reciprocal
B.J. McCallum	Real Goods	286 Wilson St.	Amherst	WI 54406			reciprocal
Carol Venolia	Carol Venolia Architect	P.O. Box 369	Gualala	CA 95445	707.884.4513		reciprocal
Alex Wilson	Environmental Building News	RR 1 Box 161	Brattleboro	VT 05301	802.257.7300	257-7304	reciprocal
Helmut Ziehe	IBE	P.O. Box 387	Clearwater	FL 34615	813.461.4371		reciprocal

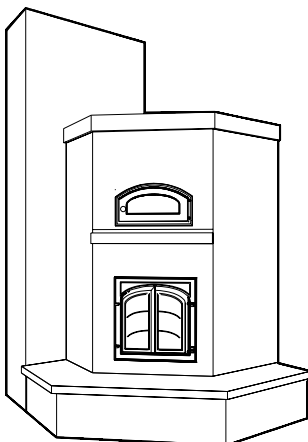

Integrated Wood Energy Systems for Sustainable Housing

Mario Kani, P.Eng.
Allen Associates
Toronto, Canada

prepared for:

The Research Division,
Canada Mortgage and Housing Corporation
Project Manager: Peter Russell

Abstract

In the context of sustainable housing Allen Associates has developed projects with renewable energy systems including wood heating. The Toronto winning design of the CMHC (Canada Mortgage and Housing Corporation) Healthy House Competition highlighted the need for a wood fired integrated appliance which combines space and domestic water heating, cooking and electricity production. This device will service reduced thermal and electrical end uses and complement photovoltaic electricity generation and solar thermal water heating.

This paper discusses environmentally sustainable housing principles and illustrates their application with three built projects. All projects used a major wood heating appliance with integrated domestic water heating.

A current CMHC project is described which is studying the technical and commercialization aspects of wood-fired cogeneration. Technologies such as heat (or Stirling) engines, steam engines and steam turbines in the range of 500W to 3000W are described as promising technologies. Wood gasification as well as the thermionic effect are also discussed. Two integrated appliances are proposed for further development.

Our present change in direction towards environmental sustainability will need to promote green technologies and necessarily relegate many established products and practices to the recycling pile. Several industries can benefit directly, including wood stove manufacturers, the mechanical tooling industry and the electrical conversion system manufacturers.

Introduction

There is an increasing recognition that all of our activities and the design of devices which support those activities must move towards environmental sustainability. Sustainable housing means that the design and construction of our houses and energy systems as well as practices in our households must move towards sustaining the ecosystems that sustain us. The concepts of high efficiency, low embodied energy, and renewable energy sources are consistent with sustainability.

It is interesting to note that though properly managed wood supply can be considered a renewable biomass, it is often considered unsustainable due to its combustion emissions, however, the problems are typically rooted in

THERE IS AN INCREASING RECOGNITION THAT ALL OF OUR ACTIVITIES AND THE DESIGN OF DEVICES WHICH SUPPORT THOSE ACTIVITIES MUST MOVE TOWARDS ENVIRONMENTAL SUSTAINABILITY

sustainability issues of the application not of the fuel source. Emission problems can occur for the following reasons:

- unique bioregion (climate)
- unsustainable urban living (car dominated, density)
- low efficiency wood burning devices
- high heat loss houses (requiring excessive amounts of wood)

Figure 2. Retained heat oven insert for masonry heater.

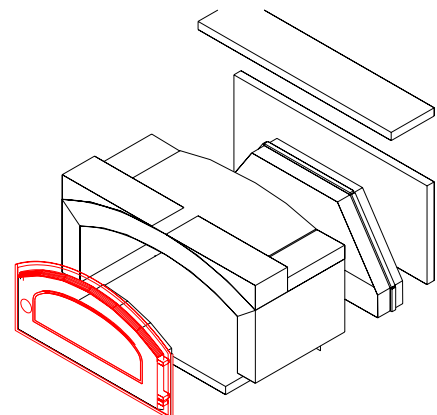

Sustainable Housing Principles

Housing development that is environmentally sustainable should have no net negative environmental impact in terms of global and local bioregions or ecosystems.

Very simply the resource inputs and outflows crossing the site boundaries should be benign whether they be energy or water. The site itself should be life sustaining as an ecosystem. Healthful indoor conditions are part of sustainable design.

CMHC has focused on "healthy housing" as a development goal in the broadest sense for their housing activities (Ref. 1). By comprehensively and consistently designing for occupant health (air, water, sensory), energy efficiency (embodied energy, renewable energy), resource efficiency (materials, waste, water) and environmental responsibility (emissions, waste water, site planning, garbage), sustainable housing is a natural result.

HEALTHFUL INDOOR CONDITIONS ARE PART OF SUSTAINABLE DESIGN

Three Buildings Approaching Environmental Sustainability

Allen Associates has been moving toward environmentally sustainable building designs, resulting in some notable projects. These projects have the following characteristics:

- high insulation levels
- low air leakage envelope
- high performance glazing
- passive solar design
- controlled ventilation with heat recovery
- high efficiency lights, appliances, fans
- renewable energy resources
- passive, non-ozone depleting cooling
- low-tox materials
- appropriate, low embodied energy construction
- extensive water conservation
- benign waste water management
- site and building greening

The following are three recent examples of existing projects that exemplify these principles. Note that all three projects have major wood heating devices with integrated water heating.

Boyne River Ecology Centre

The Boyne River Ecology Centre, designed with Doug Pollard Architect, is an 500 m² educational facility at the Toronto Board of Education's natural sciences school located on the Niagara escarpment, 100 km northwest of Toronto. A brief description of environmental features is as follows:

- Highly efficient thermal envelope, mass construction with earth coupling and sod roof for minimal heat load
- Natural ventilation via low/high windows for summer cooling. Passive heat exchange ventilation and displacement type distribution for good indoor air quality in winter
- Efficient compact fluorescent and halogen lighting with unique controls for reducing demand on the limited electricity supply
- Living machine bioregenerative wastewater treatment yielding effluent of higher quality than pond supply water
- Off-grid renewable electrical supply from 650 W photovoltaics, 1.5 kW wind turbine and two small 200 kW hydraulic turbines
- Space heat is primarily passive solar with a 7 kW central wood fireplace as back-up
- Domestic hot water heating is solar thermal augmented with wood heat in winter via heat exchangers at the perimeter of the fireplace.

Figure 3. Three dimensional computer model of a masonry heater. In this view model is cut in half and viewed in perspective.

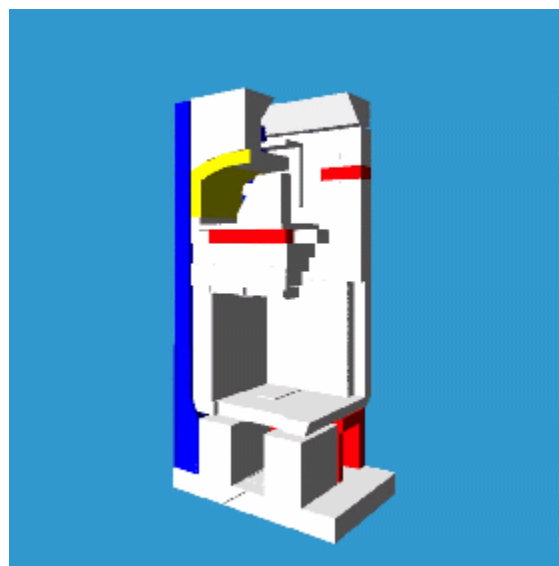

Kitchener-Waterloo YMCA Environmental Learning Centre

For the YMCA Camp KI-WA-Y Allen Associates designed mechanical systems for two buildings, the Earth Residence, a 40 person 300 m² dormitory and the Day Centre, a 250 m² administration and special function building (Architect: Charles Simon).

The Earth Residence has many common features with the Boyne Ecology Centre:

- Earth covered roof for site greening
- High performance envelope and passive heat recovery ventilation
- Clivus Multrum composting toilets and Waterloo Biofilter for grey water
- Off-grid renewable energy supply using 14 kW masonry wood heater, solar thermal, 2 kW photovoltaics and wind generation
- Recycled wood construction materials

The Day Centre will be the central focus with offices and an auditorium and features:

These projects were primarily designed to minimize environmental impact of resource consumption balanced with measures to mend the ecosystem support structure. However, the cumulative effect of executing these projects is that we now have the technology and design principles to make new and retrofit building developments, whether a single house or a community, become "environmental clean-up modules". Each construction of a housing unit is an opportunity to export renewable power, to clarify water and consume emissions by increased greening, in short, to help restore the actual ecosystem.

- Greenhouse featuring Living Machine waste treatment "garden" supplies passive solar heating via an air-coupled mass floor
- The rest of the building space and water heated by 50 kW Portage & Main wood boiler and solar thermal
- Provision for future grid-connected renewable electricity supply and future district heating of other buildings on campus from wood boiler.

Figure 4. Masonry heating system at Kitchener-Waterloo YMCA Earth Residence. Design output is 15kW including 2000 litres of DHW/day. Fuel requirement at maximum output is 300 lb/day.

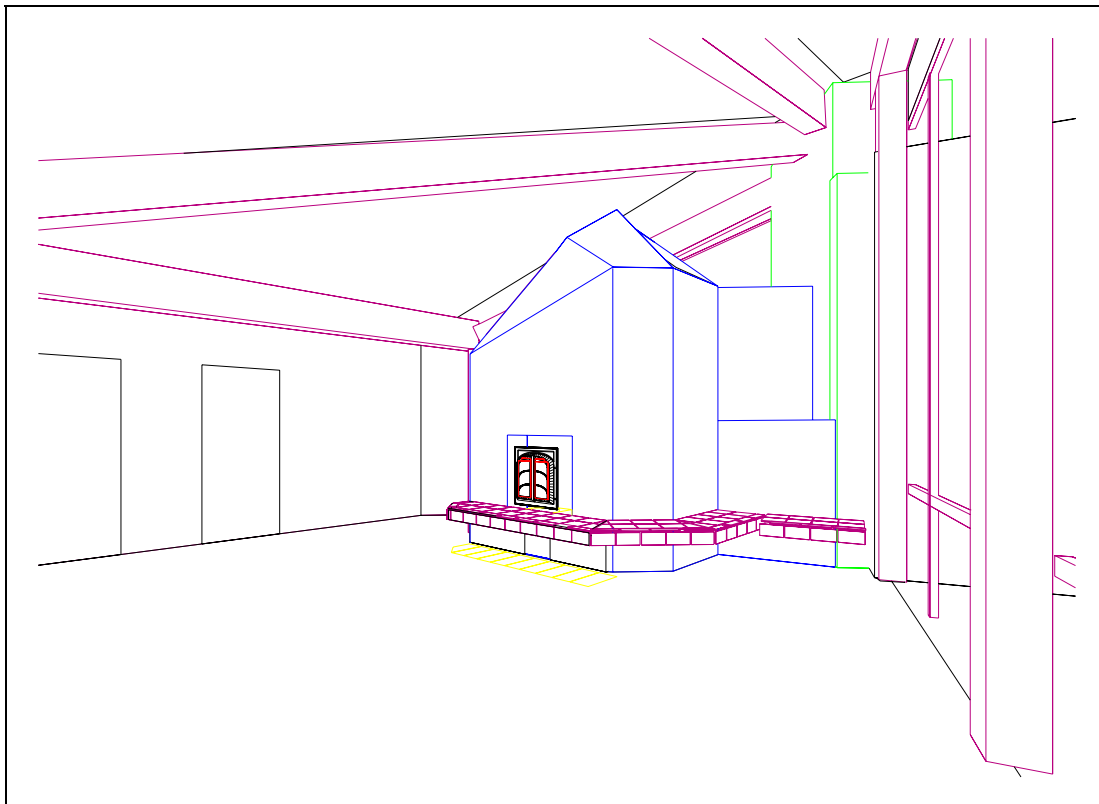

Crainford Residence

This 250 m² house is located in Toronto and includes an at-home workplace.

It has no renewable electricity supply but has a number of important features:

- Highly efficient envelope allows heating and cooling to be supplied via ventilation air stream (from heat recovery ventilator) in a combined radiant/convective mode
- Principal heating is a masonry wood heater with gas hot water tank as back-up
- Water heating is solar thermal augmented with wood heat in winter via heat exchanger in fire box
- Rainwater collected in cistern for displacing treated water
- Passive, night-sky radiation cooling (no CFC's)

Sustainable Household Energy Profile

A sustainable building design results in severely reduced energy budgets. By definition, sustainability also does not allow for waste and a wasteful energy lifestyle. As the energy and ecological designers of the Toronto winning entry of the CMHC Healthy House Competition (with Architect Martin Liefhebber) we developed a 100% renewable energy system, in effect the Unplugged House. However, renewable energy is not sustainable if it is used to power inefficient end uses. To make this proposition economically viable and sustainable, the following energy budgets were developed.

Space Heating/Cooking	2500 kWh
Domestic Hot Water	1000 kWh
Electricity	<u>1500 kWh</u>
Total	5000 kWh

Note that a conventional household is about 30,000 kWh of total thermal and electrical load and an efficient household is about 20,000 kWh.

The 5000 kWh is to be supplied by external renewable resources. The energy system consisted of photovoltaic (PV) electricity production, solar thermal domestic water heating and integrated wood-fired space heat, cooking and electricity. The rationale for wood-based electricity production recognizes the poorer solar potential in winter when space heat is required.

The 5 m² PV system is responsible for 1000 kWh of electricity and the 3 m² solar water heater for 700 kWh. The remaining 3300 kWh (2500 kWh for space heat and cooking, 300 kWh for domestic hot water and 500 kWh for electricity) is supplied by wood heat. Overall

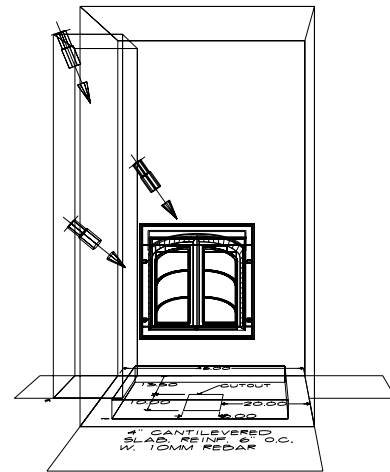

Figure 5. Masonry heating system layout for Crainford residence

combustion efficiency is a minimum of 70%. This is equivalent to about 4500 kWh or three quarters of a full cord. This is our best definition of a sustainable rate of wood consumption for a household on 0.2 hectares of woodlot which should allow for sustainable forest practices.

Integration of Water Heating

Our use of water heat exchangers have proceeded without any rigorous existing design principles or test results. The masonry heaters were supplied by Norbert Senf of Masonry Stove Builders, complete with heat exchangers. Our systems have both thermosyphoning and pumped loops. The systems are safeguarded from boiling by ensuring an automatic heat dump to additional heating devices, e.g. fin-tube convectors. These can be located where potential discomfort is not a problem, such as an unconditioned basement.

Issues of CSA approval of heat exchangers and impact on emission remain.

Integrated Wood-fired Cogeneration

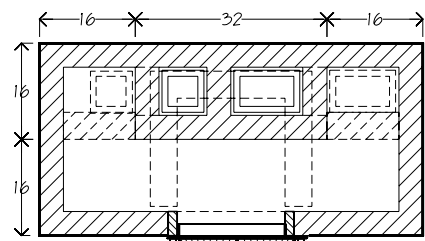

As a result of the CMHC Toronto Healthy House project the need for development of a low-output, wood-fired cogenerator at a reasonable cost was identified. Allen Associates has been asked by CMHC to conduct a study into the technical and commercial feasibility of wood-based thermal devices that could also provide electrical power (Ref. 2).

The concept typically focuses on wood combustion to generate mechanical output via steam power or directly from heat via an "external combustion" engine known as a Stirling engine. However, wood gasifier and thermopile technologies are also being assessed.

Market Feasibility

Wood burning appliances exist in a total of 1,400,000 Canadian households Wood or biomass fueled stoves are

significantly different expectations of the technology which will need to be addressed.

Alternative and complementary technologies will be reviewed to note opportunities as well as potential competition. An alternative technology is methane-producing digesters fed by compost and/or human waste, and a complementary technology is PVs which supplement electricity year-round but maximize output in summer when thermal output from wood heat has lower demand.

Technology description

The attraction of wood-fired cogeneration is the utilization of high grade heat to produce high-grade energy first (i.e. electricity); then use the thermal by-product for lower temperature demands. In essence, a

MODERN DESIGNS OF STIRLING ENGINES HAVE MECHANICAL EFFICIENCIES OVER 20% WHICH MAKES THEM THE HIGHEST MECHANICAL EFFICIENCY FOR SMALL SCALE DIRECT THERMAL CONVERSION FROM A THERMAL SOURCE.

the sole source of heat in close to 500,000 homes. For these users it is typically less costly to heat a home in this manner than with electricity or oil (if available). The economics would be further improved if electrical production for appliances and lighting were included in the scenario.

A potential market for single dwelling wood-fired cogeneration needs to be defined. There are established market for metal wood stoves, masonry heaters, cook stoves and whole-house fireplaces. In terms of housing types there are essentially three groups:

- off-grid rural low-density
- on-grid rural low density with high non-wood fuel costs
- on-grid high density (urban) with lower non-wood fuel costs

These groups of dwellings will be quantified and market penetration rates defined. In rural communities, the household scale application will compete with community systems; however, many of the houses are separated by significant distances, making it uneconomic for hook-up to district energy systems. For the off-grid case, clearly any reliable self-generation, including PV and wind, is attractive and integration with thermal functions should be a winner. Grid-connection has the attraction of export and not requiring electric storage if the meter can spin forward and backward. Ontario Hydro is just embarking on a pilot project of this type. The above identified market niches will have

thermodynamic cascading of energy outputs.

Typically the cogenerator consists of an energy source, a mechanical driver and an electric generator. A different technology using the thermionic principle, can convert heat directly to electricity.

The primary fuel source is assumed to be wood-based: pellets, chips and cord wood. A related renewable fuel source is organic solid wet waste (compostables) which can be conditioned with wood chips, sawdust or straw. This is attractive in agricultural applications. Other agricultural waste, such as rice husks (and perhaps soon hemp stalks), may be feed stock for such appliances. Dual fuel combustion units with propane back-up may also have applications.

The derived energy for input to the mechanical driver can be in the form of heat, steam, wood gas, and methane. Steam is conventionally produced in small boilers operating at pressures as low as 15 psi. Wood gas is produced in gasifiers, a technology originally developed during the second world war when gasoline was in short supply (Ref. 3). The devices are bulky and the fuel supply is "dirty" requiring special cleaning for use in conventional engines. Methane, the major component in natural gas, can be produced by anaerobic digestion of compostables. Some cleaning is also required but digesters exist that produce sufficiently clean biogas for conventional engine cogenerators, as well as a high grade compost for agricultural purposes.

Heat-based mechanical drivers are Stirling engines (Ref. 4). This device is a piston based engine utilizing a low

pressure working fluid, typically helium or air. Heat is applied to one end, expanding the working fluid thereby moving the piston. The working fluid is then cooled (or "regenerated") to allow the piston to return. The technology is intrinsically quiet in operation.

Low efficiency units have a long tradition in the third world, particularly in India. Modern designs of Stirling engines have mechanical efficiencies over 20% which makes them the highest mechanical efficiency for small scale direct thermal conversion from a thermal source. However, these units have been typically natural gas fired and availability and costs are a concern.

Temperature requirements for small Stirling engine is an issue. Operating temperatures drop when one goes from natural gas to pellets to chips to cord wood.

A Stirling engine could be driven off wood gas

Equipment Sizing

The size and profile of end use loads is critical to the equipment requirements for design purposes. This includes loads such as space heating, space cooling, water heating, cooking, refrigeration, ventilation and miscellaneous electrical uses. However, for market considerations a certain degree of efficiency in end uses should be assumed even for the high end of the range. The low end of the range is the sustainable energy profile discussed in Section 4. This will facilitate the equipment sizing by limiting the applications to possibly two electric output values in the 500 W to 3000 W range.

This sizing is sufficient for a comfortable electric lifestyle; however, electrical storage combined with automated or resident energy management is assumed.

AVAILABILITY OF SMALL ELECTRICAL GENERATORS DOES NOT APPEAR TO BE A BARRIER. CONCEPTUALLY THEY ARE SIMPLY ELECTRIC MOTORS RUN IN REVERSE: A MECHANICAL INPUT RESULTS IN ELECTRICAL OUTPUT. AS WITH MOTORS, EFFICIENCIES CAN EXCEED 80%.

combustion but overall efficiency would be low. More traditionally, wood gas has been used to drive internal combustion piston engines. While mechanical efficiency may be reasonable, the gasifier is bulky, complex and costly.

For small steam drivers there is a range of options available. Piston steam engines are typically produced for historic markets where looks are as important as operating characteristics. There also exist low pressure, paddle-wheel steam turbines. These technologies are typically no higher than 15% mechanical efficiency. There is development in small high performance steam piston engines and turbines; however, there seems to be no commercialization for lack of a defined market. Safety concerns about operating steam devices in a residential setting is also a perceived barrier.

Availability of small electrical generators does not appear to be a barrier. Conceptually they are simply electric motors run in reverse: a mechanical input results in electrical output. As with motors, efficiencies can exceed 80%.

Electricity can be generated by the thermionic effect, that is, the use of dissimilar metals can cause electrons to flow in the presence of heat. This effect is used in thermocouples which measure temperature based upon change in electric flow. A collection of thermocouples is called a thermopile. The technology has the attraction of being simply located on top of a hot surface, e.g. wood stove; however, electrical production efficiency is very low, less than 5%.

Significant electric loads of short duration, e.g. power tools, may be supplied by an additional gas generator or by power from the electric grid.

Feasible Systems and Applications

There are a number of reasons why large scale commercialization has not yet proceeded. These range from technical feasibility issues to expectation in the residential setting. Refined products need to be developed. Particular attention must be paid to the user interface issues: location, automation, loading, maintenance, safety issues and noise. However, it is both sobering and comforting to know that around the globe there are many operating systems at different stages of refinement.

The following are two possible configurations for future commercialization.

Integrated Masonry Heater/Stirling

Masonry wood heaters are thermal storage stoves which operate with fast, clean, high temperature burns. This design has an additional high temperature mass (e.g. a soapstone slab) located at the hottest part of the flue to provide several hours of stored heat for the Stirling engine. Lifting insulated lids on the slab will allow cooking to take place. An oven is also part of the design. The stove top is insulated when not used for cooking. In summer, when cooking only is desired, most of the mass can be bypassed by the flue gasses. The electrical output is between 500W and 1000W. This appliance is assumed to operate with complementary PV electricity production and solar thermal water heating. Water is heated at the heat rejection of the Stirling engine to assist the solar water heater.

Separated Steam Generator

Due to potential noise and safety concerns a steam generator would also more likely be separated from living space. The combination is a small, low-pressure steam boiler feeding a piston engine or turbine. Space heating and domestic water heating can be supplied via heat exchangers from the steam directly or possibly after the mechanical device. This device may be fired on electricity demand all year, if no other renewable sources are available. In summer heat will need to be dumped to outside if no thermal loads exist. However, absorption cooling and refrigeration may be considered to improve the utility of the steam.

Prototypes of the best technologies with less integration exist both on this continent and globally. Research and development will be required to produce market ready product. Private sector funding must take the lead as it is in the industry's interest to shape future market opportunity. Prudent, strategic government support during development is amply paid back in job creation and new economic activity.

Conclusion

We must embark seriously and rapidly on the road to environmentally sustainable energy consistent with the development of sustainable housing. New wood biomass integrated energy systems, likely complemented with other renewable energy forms, will play a very significant role in our energy future.

Their success depend upon appropriate application, economics, reliability, user friendliness and currency with environmentally appropriate advancements.

It is always difficult to bring new product to market. Having identified key markets and penetrations rates, the challenge is to position the developed product correctly for sales to accrue. The barriers are typically numerous in any endeavor; by sustained effort, all but the most fundamental can be overcome. The key is to turn barriers as much as possible into opportunities.

For example, the downturn of the housing industry and North American restructuring of manufacturing allows for significant opportunity to set up local manufacturing and importing of advanced components, with a better climate of implementation than would exist in an overheated residential market.

Our present change in direction towards environmental sustainability will need to promote 'green' technologies and necessarily relegate many established products and practices to the recycling pile. Several industries can benefit directly, including wood stove manufacturers, the mechanical tooling industry and the electrical conversion system manufacturers.

References

1. Canada Mortgage and Housing Corporation. CMHC's Healthy Housing Competition: Guide and Technical Requirements. Ottawa, 1993.
2. Allen Associates. Technical and Commercialization feasibility of Household Scale Wood-fired Cogeneration. Study for CMHC, in progress.
3. Solar Energy Research Institute. Handbook of Biomass Downdraft Gasifier Engine Systems. Golden, Colorado, 1988.
4. Walker, G. et al. The Stirling Alternative. University of Calgary, Calgary, Alberta, 1990.

ELEMENTS OF SUSTAINABLE HOUSING

- high insulation levels
- low air leakage envelope
- high performance glazing
- passive solar design
- controlled ventilation with heat recovery
- high efficiency lights, appliances, fans
- **renewable energy resources**
- passive, non-ozone depleting cooling
- low-tox materials
- appropriate, low embodied energy construction
- extensive water conservation
- benign waste water management
- site and building greening

Heating Water with Masonry Heaters

Norbert Senf
Masonry Stove Builders

Introduction

An electric domestic hot water heater usually accounts for the largest portion of a household's electricity bill, assuming that electricity is not used for space heating.

Natural gas, where available, is less costly. However, it is still a non-renewable resource that contributes to global warming.

Part of the heat output of a masonry heater can be used to heat water. The water can be domestic hot water or water used for space heating (i.e., in a radiant floor system). While this article is specific to contraflow heaters, similar principles apply to all other masonry heaters.

A heat exchanger consisting of one or more loops of stainless steel high pressure boiler tubing is located against the back of the firebox, in the hottest part of the fire.

It is very important to install the proper safety devices when adding a hot water coil. If water in the coil is allowed to turn to steam, an explosion could result. Also, the water in the tank can reach scalding temperatures, so that a tempering valve may need to be used. Never take any shortcuts when designing or installing a domestic hot water loop into a wood fired masonry heater.

Thermosyphon Method

The heat transfer can take place in two ways, by thermosyphoning, using natural convection, or by means of a small circulation pump.

A thermosyphon system is the simplest, but also has some drawbacks. It requires that the storage tank be located higher than the coil. Best efficiency is obtained when horizontal distance to the tank is 4 ft. (1.2 m) or less and the vertical distance is 6 feet (1.8m) or more.

This arrangement is often not convenient because the domestic hot water tank is usually located in the basement. Sometimes you can get around this by adding a preheat tank. The preheat tank is located for good thermosyphoning and is plumbed to feed into the cold water inlet of the primary tank.

Heat transfer is lower with the thermosyphon method due to the slower water flow through the

stainless loop(s). In order to achieve good efficiency, both lines from the coil to the tank should be insulated. A minimum of 3/4" dia. pipe must be used to ensure adequate flow.

Figure 6. Hot water system—thermosyphon method

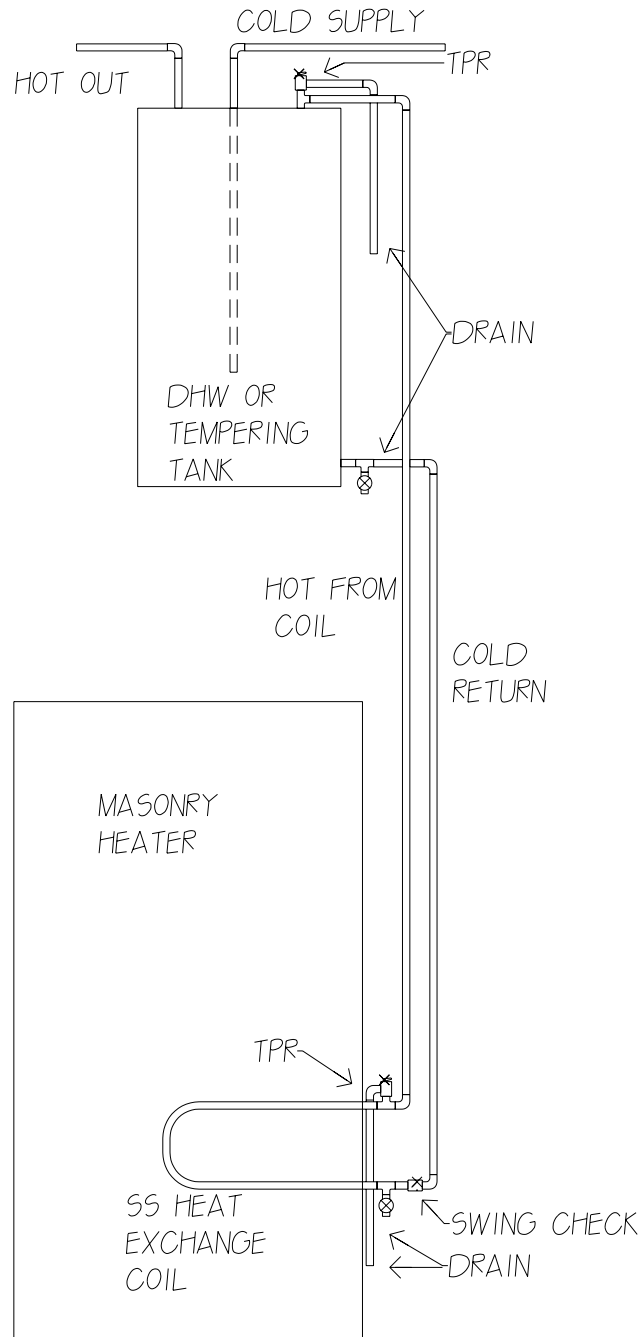

Circulation pump method

This method allows the most flexibility in locating the tank(s) and provides the greatest amount of heat transfer. A small pump (1 - 2 gpm or 0.07 - 0.15 l/s) is used to circulate water between the coil and the tank.

A controller is required to sense when the heater is being fired or the water from the heater is warmer than the water in the tank. Since a considerable amount of heat is stored in the firebox after a burn, water heating occurs for some time after the fire is out.

Two temperature sensors are used. One sensor is placed at the hot water outlet from the heater. The other sensor is placed at the tank where cooler water leaves the bottom of the tank on its way to the loop. A differential controller uses the temperature sensor information to determine when to turn the circulation pump on and off.

Required safety devices

Temperature/pressure relief (TPR) valve

In all cases, it is necessary to install a temperature/pressure relief (TPR) valve at the hot water outlet of the coil, near the heater. A TPR valve is a standard plumbing item used on hot water tanks. In case of a temperature or pressure buildup, steam and/or excess hot water are safely diverted into the house drainage system. The valve should be accessible for servicing and testing.

The TPR valve is in addition to the TPR valve that is normally located at the hot water tank, and should not be used as a substitute for the tank TPR valve.

Coil construction

The only material used for the coil in the firebox should be certified Schedule 40 stainless steel high pressure boiler tubing, rated at 16,000 psi (for 3/4" pipe). Both ends of the coil should be threaded. A minimum of 3/4" copper tubing should be used for the coil loop to the tank.

Figure 7. Hot water system—circulation pump method

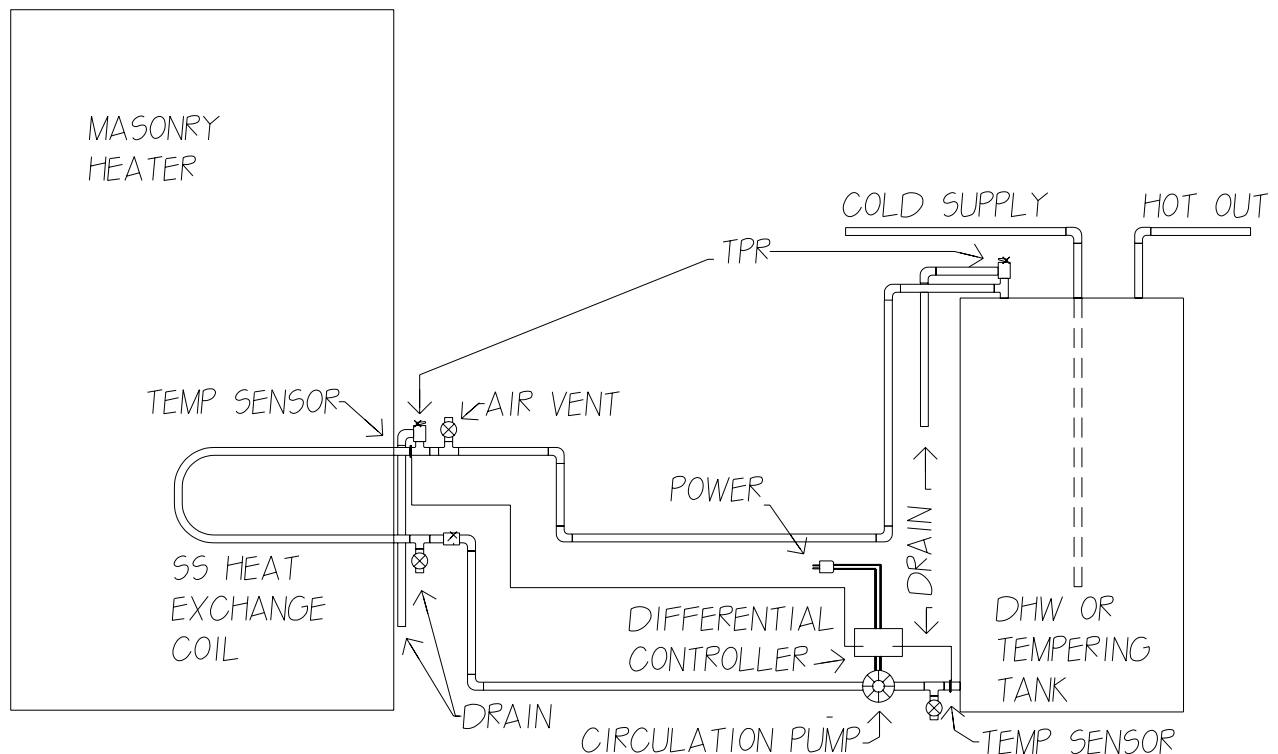

Recommended safety devices

Tempering valve

If hot water usage is low, water in the tank can reach scalding temperatures. A tempering valve can be installed at the tank exit to mix cold water into the hot water line.

Tempering tank

A second tank can be installed to increase the capacity of the hot water system. This is known as the tempering tank method. It is often useful in thermosyphon systems (see above). For both types of systems, it has the advantage of being able to utilize more low-grade heat from the heater during periods of high usage. During high usage, water in the tempering tank will be cold. For a thermosyphon system, this creates a higher temperature differential for convection and increases flow in the loop and therefore heat transfer. For both types of systems, it allows low grade heat from the firebox to be utilized for a longer time after the fire is out, since the feedwater to the coil is cold.

Swing check valve

A swing check valve is a one way valve that is installed in either the thermosyphon or the pumped loop. In both cases, a low resistance valve designed for horizontal installation should be used. It is installed near the heater at the water inlet side of the coil. The valve body is stamped with an arrow to indicate the direction of flow.

With a pumped system, it prevents reverse thermosyphoning when the tank is lower than the heater and the heater is cold.

With either a pumped or a thermosyphon system, it can act as a secondary safety device. If a bubble of steam forms in the coil, it creates an immediate pressure rise in the system. This pressure pulse will first reach the (now closed) swing check valve, where it will reflect. This reflection creates a momentary low pressure at the swing check valve, allowing some cold water to pass. This mechanism can create a pumping action that helps to circulate water through the coil in case of an emergency, such as a power outage.

Drain fitting

The coil loop should have a drain fitting to allow for servicing. Once a year, the loop should be flushed with water. In areas with hard water, the loop should be checked for scale buildup. This can be indicated by dislodged particles of scale coming out of the drain fitting during flushing. It may be necessary to use a cleaning solution to remove any scale buildup.

Air vent

It is a good idea to install an air vent at the high point in the hot water loop circuit. You can use either an automatic vent or simply a gate valve to allow the manual purging of any air that becomes lodged at the high point. This is more of an issue with a pumped system, since the tank is usually lower than the loop.

Operation

Power failures

Since a masonry heater is typically fired for about 2 hours out of 24, the odds of experiencing a power failure during a full burn are reduced accordingly. However, if power failures are a regular occurrence in your area, you should give due consideration to this fact when deciding what level of protection to install.

If an emergency occurs during a burn, you can cool the firebox by making sure that the flue damper is wide open and then opening the firebox doors. If unacceptable smoke spillage occurs, open the doors as far as possible without causing spillage.

If your water supply is from city mains, then pressure will be maintained if the TPR valve vents hot water into the drain. Follow the annual maintenance checklist, below, to keep your system in shape.

If your water is from a well, then you will lose water pressure soon after a power failure. If water boils in the coil and is vented by the TPR valve, you may get air in the coil. If the coil is allowed to get hot enough, it may melt soldered connections. After an emergency of this type, shut off your water and check the system for leaks. You may be able to do this by restoring water pressure in a gradual way.

Optional safety devices

If you feel that your degree of risk warrants it, ie, you have a circulation pump system *and* you are in an area of frequent power failures that result in a loss of water pressure, you can drive the loop with a 12 volt circulation pump. Power the circulation pump with a 12 volt car battery that is maintained by a trickle charger.

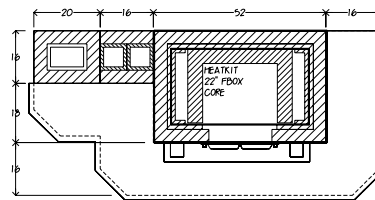

Washington State Fireplace Emissions Standard Under Way

John Crouch

Local Government Affairs
Hearth Products Association
916.974.1188
FAX 974.8380

A Technical Advisory Group (TAG) has been meeting in Washington to craft the state's Fireplace Emission Standard. The TAG will provide their report to the State Codes Committee that will then forward it, after discussion, to the State Building Code Council. Public hearings on this proposal should be some time in late summer or fall.

Wayne Terpstra of Heatilator is seated on the TAG in its current capacity as chairperson of HPA's Fireplace Technical Committee. Other HPA and HPA-C (Hearth Products Association of Canada) members in attendance at the TAG meeting were John Mitchell of RSF Energy, Fred Rossiter of Elco Northwest, Walter Moberg of Firespaces, Jerry Frisch of Lopez Quarries, Paul Tiegs of Omni, Jim Davies of Kilsap Chimney Service, Randy Weller of A.E.S., Marty Husted of Majestic, and Tom Stroud of Dietmeyer, Ward & Stroud. HPA's John Crouch has also closely monitored all of the meetings.

The masonry fireplace industry has been represented by Rick Crooks of Mutual Materials and Jim Buckley of the Masonry Fireplace Association. Chuck Murray of the Energy Office and Jamie Craighill of the State Department of Ecology have represented the state of Washington and David Scott of the State Building Code Council have staffed the group.

In creating the first state fireplace standard in the U.S., the TAG has recognized the unique differences between wood stoves and fireplaces. Using information from EPA's document, AP-42 Emission Factors, the TAG has set the standard for fireplaces at 7.3 grams/kilogram of fuel. This emission factor is commensurate with the field performance of EPA Phase II wood stoves, and is indicated in units of smoke/unit of fuel burned, rather than per hour, as is the case with wood heaters. In addition, the TAG agreed that the enabling

legislation allowed them to create a system that will only report if an appliance passes or fails the test, and the specific g/kg number. The TAG also agreed to allow masonry fireplace systems to meet a different emission factor for the first two years.

In June the TAG spent a great deal of time on the details of the test protocol. Paul Tiegs had been asked by TAG to create a test method based on his years of experience in wood burning testing. The TAG has used most of Paul's suggestions and has created a method that can be used for either factory-built or masonry products. The method allows the use of either Douglas Fir splits, or Douglas Fir 4x4's as a test fuel.

The process is far from finished and it is still premature to begin testing to meet this new standard. It is clear, however, that there will be a standard in place in time to meet the deadline of January 1, 1997.

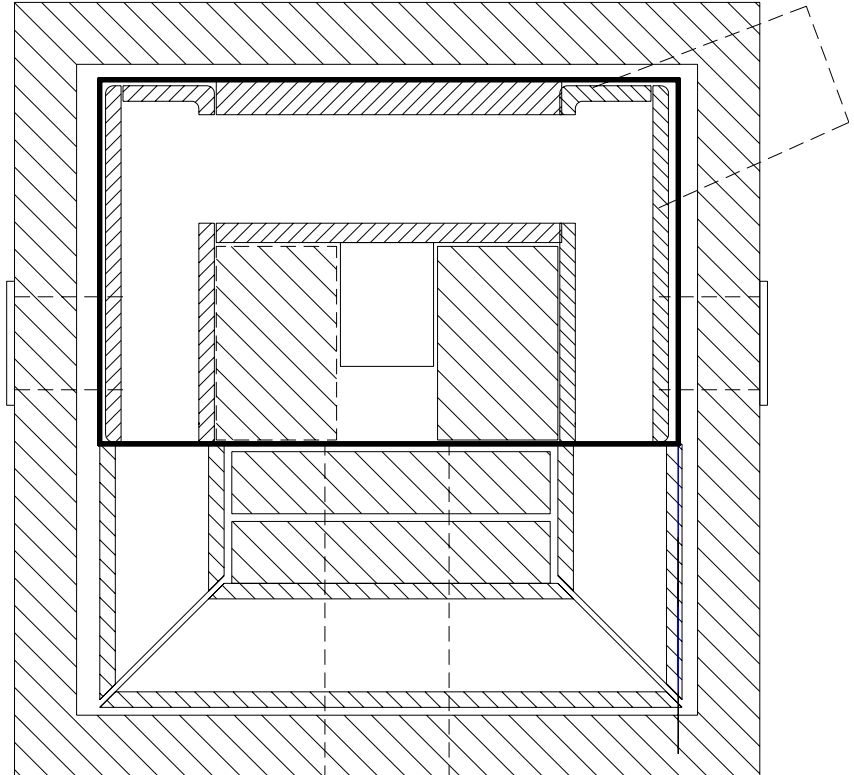

Figure 8. Heated bench layout for contraflow heater

Space Heating and Fireplaces: The View from CANMET'S Combustion Laboratory

A.C.S. Hayden, P. Eng.

Combustion and Carbonization Research
Laboratory/ERL/CANMET
555 Booth Street
Ottawa, Canada K1A 0G1

THE ART OF FIRE

Wood-Gas Forum 95, Toronto, June 1995

INTRODUCTION

Improvements to the building envelope, both in terms of insulation and in terms of air tightness, are reducing the amount of energy actually required for heating new and renovated housing. Lower energy housing requires alternative means to generate and supply the heat. Sizing of equipment for low energy housing becomes increasingly important. Most of the heating season, conventional equipment can result in overheating, in short, uncomfortable bursts of hot air, or in equipment cutting out on high limit before actually heating the house.

Conventional fireplaces mate increasingly poorly with such housing due to their gross inefficiencies, large air requirements, pollutant emissions, and effects on indoor air quality. These appliances are incompatible with today's new and renovated housing.

New designs, in the form of advanced combustion wood fireplaces and direct vent gas-fired fireplaces have the potential to convert a most difficult problem into a solution which is safe, energy-efficient and environmentally benign.

FACTORS AFFECTING HEATING APPLIANCE PERFORMANCE

It is worthwhile to examine the prime factors which affect the performance of a heating appliance over the entire heating season.

There is a close relationship between the house and the heating appliance, with the relationship similar to the fundamental one of economics - demand and supply, as seen in I (1). On the left side are the Demand Factors - the reasons why heat is required; on the right side are the

Supply Factors - the ability of the appliance to supply the heat.

Demand is controlled by the inside temperature requirement and the colder outside temperature. At the same time, the house is constantly losing heat through two basic mechanisms, Transmission Losses and Ventilation Losses. **Transmission Losses** are losses through the fabric of the structure. **Ventilation Losses** are due to the passage of air through holes in the structure. The common ventilation loss is the infiltration/exfiltration through cracks (around doors, windows, sillplates, etc.). A second component is directly attributable to a vented fuel burning appliance. When the appliance is off, there can be a direct opening to the outside via the chimney, through which warm air from the house and the appliance heat exchanger can escape, or cold, outside air can enter the house.

The **Supply or Performance Factors** measure how well the heating appliance can supply the heat required. Five aspects must be considered:

- (1) **steady state efficiency** - commonly determined by stack temperature and excess air (as obtained by CO₂ or O₂ in the flue gas), once the appliance has reached equilibrium (steady state). However, it can take appliances a very long time to get to steady state. Until then the appliance is in the ...
- (2) **transient state**. In general, most physical systems work much more efficiently in steady state. Just imagine your car. You use much more gasoline per kilometre accelerating and decelerating driving around the city than you do cruising on the highway. Similarly, an appliance is generally more efficient at steady state than in the transient condition. Combustion appliances spend much of their on-time running in the transient state. The combustion air requirement is about the same for both steady state and transient operation. It represents only about 1.5% of the house heat load over the heating season.
- (3) **dilution air** through the draft dilution device accounts for a much larger air requirement and heat loss than does the air actually required for combustion - anywhere from 2 to 10 times the latter, representing 3% to 20% of the overall house heat requirements. The main purpose of this device is to isolate the burner from outside pressure fluctuations. New technologies such as induced draft fans, pulse combustion or high pressure drop burners can eliminate the need for dilution air and the losses and problems entailed therein.
- (4) **combustion efficiency** measures the degree to which the fuel is completely burned. For oil- or gas-fired systems it is usually greater than 99.6%. For conventional wood-fired systems it can be much lower,

often in the 90% range, representing a significant heat loss.

(5) Another important factor is **how the heat is supplied** to the area requiring it. Efficient energy is energy where you want it, when you want it. If the area is overheated unnecessarily/undesirably, it is not efficient. If the heat extracted from the flue gases by the appliance is not supplied to the area, but rather is dissipated elsewhere (eg. duct losses from central furnace; casing loss from fireplace to outside masonry) it is not efficient. The combination of all these Performance Factors work together to give what is called the Seasonal Efficiency or, ideally, the regulated Annual Fuel Utilization Efficiency (AFUE), a measure of how efficiently the energy in the fuel is actually supplied to the house over the entire heating season.

Combustion Spillage

After the fireplace is lit, and before the fireplace chimney gets hot and begins to draw properly, the chimney is often not capable of handling all the combustion products from the fireplace. This results in smoke spillage into the house, with the tell-tale indicator of a darkened mantle. During this period, the prime pollutants which can enter the house from the fireplace are carbon monoxide and particulates, including soot and PAH's.

The depressurization caused by the fireplace under high burn results in the fireplace "searching" for air. Often the most convenient source is down the chimney of the central furnace or water heater. This can disrupt the combustion and bring the combustion products of these appliances into the house.

At the tail end of the burn of the fireplace, the wood has

FIREPLACES HAVE LONG BEEN A STAPLE OF NORTH AMERICAN HOUSEHOLDS. EVEN TODAY, BUILDERS FIND IT DIFFICULT TO SELL A NEW HOUSE WHICH DOES NOT HAVE A FIREPLACE

Conventional Fireplaces

Fireplaces have long been a staple of North American households. Even today, builders find it difficult to sell a new house which does not have a fireplace. However, the mythological attraction of cosy fireplaces does not often translate into reality. Most fireplaces are difficult to start, smoke and result in unpleasant, cold drafts. They are also either the source or the driving force of toxic pollutants being released to the indoor environment.

Air Requirements

Table II (7) presents a summary of the air requirements of various residential combustion equipment, in terms of the number of air changes per hour (AC/h) and actual air flow rates, for a typical Canadian house. The measure of air tightness of a house is most often given in terms of air changes per hour, with air change being the total volume of air present in the house. 0.3 to 0.5 air changes/hour are considered necessary to ensure that there is no long term build-up of contaminants in the house. Many new, tight homes require forced ventilation systems to achieve this level.

Conventional woodburning fireplaces have massive air requirements, due to high, uncontrolled burning rates and high excess air levels. Such a fireplace can have air requirements on the order of 680 m³/h, or about **1.4 air changes per hour**. This can cause problems in most housing.

Conventional oil and gas furnaces have air demands on the same order as the 0.5 AC/h air change rate of many tight houses.

progressed to nearly pure charcoal. The fireplace can spill toxic carbon monoxide (CO), due to either of two factors:

1. particularly with an outside chimney, the draft decreases to the point that the house itself with its natural internal up-flow can become a better chimney than the fireplace;
2. other exhausting appliances such as the furnace or water heater may take their air down the fireplace chimney.

This potential for CO poisoning, usually after everyone is sleepy and is going or has gone to bed, has few obvious warning signs.

Air Pollution

Contrary to popular wisdom, conventional fireplaces can be high sources of air pollutants (4). As shown in Figure 1, CCRL experiments indicate that fireplace particulate emissions can be on the order of 50 g/h, twice the level of conventional "dirty" wood stoves. Visually, these pollutants are often not obvious, because they are diluted with the high fireplace excess air levels.

Efficiency

In most homes, conventional wood-burning fireplaces are between +/-10% efficient. They supply little if any energy to the house. Field trials conducted by CCRL in Canadian homes (1,2) showed that, on cold winter days, use of conventional masonry fireplaces actually resulted in an increase in fossil fuel consumption for heating. This means that the fireplaces actually had a **negative energy efficiency** during the period.

People have been trying for years to improve the performance of conventional fireplaces, adding this, changing that, etc., to little or no avail, but often at significant cost. Devices such as glass doors, "heatilator" type heat exchangers and even outside air supply improve the efficiency only marginally, at the very best to the 10-20% level.

The **inefficiencies of conventional fireplaces** arise for a number of reasons:

1. High excess air for combustion The more air required for combustion, the more inefficient is a combustion appliance. For example, reducing the excess air on an oil furnace from 100% to 50% can result in a seasonal efficiency increase of about 15%. With a fireplace, the heat losses due to the very high excess air levels are immense.

has been reduced dramatically, as tempered glass is effectively opaque to infrared radiation. Other units have some natural convection and/or low quality circulating fans to take some of the heat from the outside of the casing and get it into the house, but these are usually very weak and inefficient.

6. Typical location on outside walls For a fireplace on an outside wall, the common installation in North America, heat is easily lost from the fireplace casing directly to the outdoors.

The main thing to remember is that as long as fireplaces run at high excess air levels, they are inherently very inefficient, no matter what else you do.

Conventional Fireplace "Solutions"

A ROARING FIREPLACE CAN USE THE EQUIVALENT OF 1.4 AIR CHANGES PER HOUR. TO WARM THIS AIR UP FROM A COLD OUTSIDE TEMPERATURE AND THE IMMEDIATELY EXHAUST IT UP THE CHIMNEY CAN BE A MAJOR ENERGY REQUIREMENT

Figure 2 shows the maximum possible efficiency attainable for a fireplace which had a 300°F stack-entering temperature, at 4 different excess air conditions. At 1500% excess air, the maximum possible efficiency, assuming that **all** the heat was transferred to the house and that **no** house air was used is only 20%.

2. Large house air requirements This results in taking large quantities of heated house air directly out of the house. As stated previously a roaring fireplace can use the equivalent of 1.4 air changes per hour. To warm this air up from a cold outside temperature and the immediately exhaust it up the chimney can be a major energy requirement. From the previous example, if the loss due to heated house air being pulled up the stack is also considered, the efficiency approaches zero. Furthermore, when the fireplace is cooling down or not running at all, the chimney affords a large hole for heated air to escape the house.

3. Incomplete combustion If all the carbon and hydrogen in the wood are not completely burned to carbon dioxide and water vapour, respectively, there is an additional energy penalty due to "fuel" going up the chimney. For conventional fireplaces with relatively poor combustion, this heat loss can be in the range of 2-12%.

4. Minimal heat exchange In most fireplaces there is not much heat exchange surface to extract the heat from the combustion gases and transfer it to the appliance.

5. Inadequate methods of heat transfer to the house Old-style masonry fireplaces relied primarily on radiation from the flame to heat the area in front of the fireplace. New fireplaces tend to have glass doors. With most glass doors being made from tempered glass, this radiant heat

To ensure that fireplaces do not cause problems and major heat losses, the most straight-forward solution is to seal them up and not use them. However, in most cases, this is not acceptable - people want their fireplace.

Another solution is to attempt to isolate the fireplace from the house with "tight" fitting glass doors and an outside combustion air supply directly to the firebox. Some glass doors can cut down somewhat on the maximum air requirements of the fireplace, reduce the risk of spillage, as well as lower the heated house air loss during the overnight period. The radiant heat from the flame is lost, however. The outside air supply can create problems. Under significant negative pressure at the wall due to wide-induced eddying, the air supply duct may become the flue gas exhaust with a high risk of fire.

While these actions may reduce the negative aspects of the fireplace, they still do nothing for its low energy efficiency.

Artificial (manufactured) firelogs, particularly those with a paraffin base, can lower the high air demand, reduce pollutant emissions by up to 80% (4) and significantly lessen the chances of combustion gas spillage into the house. They provide almost no heat and can be quite costly if used more than a few times a winter.

Advanced Combustion Fireplaces - a Preferred Option

Finally, however there is a real solution for a wood burning fireplace - an advanced combustion, clean burning, efficient appliance.

Concern over air pollutants from woodstoves has resulted in emissions standards being set. The net effect has been a dramatic improvement in performance.

Advanced combustion woodstoves (10) have clean, efficient combustion in the firing range required by North American homes. They have an 80% reduction (6) in emissions of incomplete combustion products with a 10-20% gain in efficiency, relative to the first generation airtight stove.

Such appliances can be an effective complement to

reduced 10-fold from a conventional fireplace, while potentially supplying energy to the house at up to 70% efficiency. In order to ensure this performance, the unit should meet the emissions criteria of either EPA 1990 or CSA B415.

Only these types of advanced combustion fireplaces may be installed in Canada's R-2000 housing.

As the fireplace is usually located in a major living area, with an "open" view to other regions, these advanced design fireplaces can become extremely effective space heating systems (8). If people are increasingly comfortable in the area where they spend the majority of their time, the overall heat demands of the house can be lowered, through a de-facto zoning system. The real seasonal efficiencies of such installations can surpass their laboratory-tested efficiencies.

THE SMALL BUT VIGOROUS NORTH AMERICAN INDUSTRY HAS MADE SIGNIFICANT STRIDES IN PRODUCING MUCH IMPROVED MASONRY HEATERS IN RECENT YEARS.

conventional heating systems in many regions of the country; they offer the potential to displace 50-80% of the fossil fuel used for central heating in these regions, with a similar reduction in overall CO₂ emissions.

Suddenly there is a real solution to the conventional fireplace, which can be attractive to homeowners. Advanced combustion designs similar to those utilized with the advanced combustion woodstoves are being utilized to produce what can be called the **ADVANCED COMBUSTION FIREPLACE**.

Importantly the flame is exceedingly attractive to watch. There can be two simultaneous combustion zones. The first is the conventional flame of woodburning, while the second, immediately above, is an intense turbulent flame. The overall result is a riveting chaotic flame, much more interesting than that from a normal fireplace.

Design Characteristics Along with its advanced combustion design, this new fireplace has air-tight doors, a hot air-swept clean ceramic glass window with good infra-red heat transmission, an insulated outer casing, good heat exchange and an effective circulating fan to modulate heat supply heat to the house.

The **air requirements** of these advanced fireplaces are as low as 0.04 AC/h, so there is minimal interaction with the house air, either in releasing indoor pollutants or in causing other combustion appliances to spill. If desired, they can be connected directly to an outside air source, without the danger of path reversal which exists with conventional fireplaces.

Emissions The emissions of incomplete combustion products of the advanced combustion fireplaces are

Masonry Heaters

This is another type of fireplace (10) that has the potential for clean burning and good efficiencies. Similar units have been common in Europe for a long time, but until recently have been rarely sold in North America. The small but vigorous North American industry has made significant strides in producing much improved masonry heaters in recent years.

In this type of unit, wood is burned at a high rate for a short period. This high burning rate, coupled to good combustion design and reduced excess air, can yield low emissions and higher efficiencies. The hot flue gas leaves the combustion chamber and passes through massive masonry (often with a reverse flow path) where much of the heat from the gas can be extracted and stored. Ideally, the masonry subsequently releases the heat to the house slowly over a long period. To ensure that this happens, it is good practice to build this type on an inside wall. Outside air for combustion is another desirable feature.

Guidelines are being developed to allow good designs of this energy generator to be properly utilized as a clean, effective heat source in energy efficient housing. These have already been applied to R-2000 housing.

Pellet Fireplaces

Pelletized fuels from wood and other biomass wastes can also be utilized in efficient, clean burning **pellet fireplaces** (4). The ease of handling and automated feed tend to compensate for the higher capital and fuel costs. While more commonly used as stoves, pellet burning fireplaces are also available. To get a clean burning, efficient unit, get one that has been tested to EPA 1990 or CSA B415 criteria; otherwise high excess air can result in low efficiencies. As well, it will ensure that your unit has the potential to burn cleanly. Just being a pellet stove does not guarantee this.

tempered glass-doored, natural draft units with draft hood, to glass-doored powered exhaust units, to direct vent sealed-doored appliances.

While many can be excellent performers, the promise is not realized with others, in spite of manufacturers' claims. Standards for measuring gas fireplace efficiency have been inadequate or inappropriate, until recently. This may be changing. The Canadian Gas Association has been developing a seasonal efficiency standard for gas fireplaces P-4 (Draft O) (9). The goal of this standard is to accurately represent the seasonal performance of gas fireplaces as they would normally be installed in Canadian housing.

When a range of gas fireplaces were tested to a draft version of this new standard, dramatic differences in efficiency have been seen for various technologies,

GAS LOGS WILL NOT SUPPLY ANY REAL HEAT TO THE HOUSE, AND CAN BE CONSIDERED AS A WASTE OF A PREMIUM FUEL. GAS LOGS ARE NOT RECOMMENDED FOR INSTALLATION IN TODAY'S NEW OR RENOVATED HOUSING.

Gas-Burning Fireplaces

In the past few years, gas fireplaces have seen dramatic increases in sales, due to their convenience and clean burning characteristics. There is a number of gas fireplace types available, with wide differences in their performance characteristics.

Gas Logs

Gas logs consist of some non-combustible artificial logs mounted over gas burners, often with the whole package sitting in a metal tray. They often appear to be the cheapest way to convert an existing wood fireplace to gas.

However, this can result in a number of problems. If the fireplace chimney is not properly sized and relined, the chance of flue gas condensation and chimney degradation is high, due to high flue gas moisture, a low burning rate and low flue gas temperature. If the fireplace is on an outside wall, there is a good chance that chimney draft will be inadequate, the house may be a better chimney than the chimney itself, and the combustion products will be brought directly into the house, with indoor air quality problems. These logs will not supply any real heat to the house, and can be considered as a waste of a premium fuel. **Gas logs are not recommended for installation in today's new or renovated housing.**

Gas Fireplaces

Complete gas fireplaces offer the potential for good, efficient performance. The range of gas fireplaces available goes from natural draft units with open front, to

ranging from less than 10% to over 70%, although nearly all had been claiming 70-80+% efficiency.

Canadian provinces and the Federal Government have taken the tack that gas fireplaces can be a significant user of energy in the home and as such, their efficiencies or an appropriate measure thereof will soon be regulated to a minimum performance level.

Direct Vent Gas Fireplaces From the preliminary tests done to P-4 to date, by far the best performing gas fireplaces are those utilizing a direct vent.

Superior Gas Fireplace Design Desirable design characteristics for enhanced efficiency include direct venting, a sealed, radiation-transparent ceramic glass viewing "door", a gas log-flame combination that enhances radiant heat, intermittent ignition or comparable non-continuous pilot, good heat transfer to the house, an insulated outer casing and an effective sealed air supply and venting system to ensure safe removal of the combustion products.

Vent-Free Gas Fireplaces Recently, another form of gas fireplace with no external vent for the combustion products, with firing rates up to 40 000 Btu/h, has begun to be installed in many locations across the United States. This appliance is known as the vent-free gas fireplace. It is cheap to install and can be placed anywhere in the house, features attractive to builders and renovators. The combustion products are brought directly into the room. Efficiency can be very high, because the flue gases can condense anywhere, especially on cold outside walls and windows. Moisture build-up in the house from the flue

gases can be significant. The appliances are equipped with an oxygen-depletion sensor, which will shut off the burner if the oxygen level in the room falls below a certain level. However, all combustion products, carbon dioxide, carbon monoxide, nitrogen oxides, etc., are brought into the indoor environment and can have a negative influence on indoor air quality. Would you close off the vent of your mid or high efficiency gas furnace and exhaust it into the house? Why do it with a fireplace? Vent-free gas fireplaces are not permitted in most areas of Canada. One might better say, "**Vent-free gas fireplaces have no place in today's Canadian housing**".

Potentials for New Generation Fireplaces

For the foreseeable future, North Americans will continue to demand fireplaces in their homes. However, house

Conclusions

1. **Conventional wood burning fireplaces** are extremely inefficient, are sources and/or causes of serious indoor air quality problems, and can result in life-threatening situations. They are **incompatible with modern housing**, or with housing which has undergone energy retrofit/renovation.
2. Advanced combustion wood burning fireplaces meeting performance levels of ERP1990 or CSAB415 have low pollutant emissions. **Only these wood burning fireplaces should be installed in new or renovated housing**. Such equipment, if properly located, can have seasonal efficiencies greater than conventional gas or oil furnaces.
3. **Well-designed and properly installed masonry heaters** present a potentially clean burning, efficient alternative.

WELL-DESIGNED AND PROPERLY INSTALLED MASONRY HEATERS PRESENT A POTENTIALLY CLEAN BURNING, EFFICIENT ALTERNATIVE

heat demands getting lower and lower and, at the same time, fireplace efficiencies are getting higher. An increasingly difficult problem becomes - how to allow the use of the fireplace without causing intense overheating, especially as the outside temperature warms. On the other hand, this lower house heat demand may well start to make people ask questions like "Why do I need 3 combustion sources - for a furnace, a water heater and a fireplace - when I really don't need much heat?"

These present real opportunities for fireplaces, but ones that also require new intelligent designs and controls, integrating some if not all of these energy requirements in one piece of equipment - a **new generation integrated fireplace**. However, even if we can develop such an appliance, it will not be enough to leave it at that point. Careful integration with the house design and layout will be required, following the "**house as a system**" approach.

If all of the considerations of the previous paragraph are not followed, the opportunity for the fireplace to become the centre of all house operations will be lost; the fireplace will remain in its present position as a decorative addendum to the house.

A further large market opportunity exists for such a new generation fireplace in as many as 20% of existing Canadian households - those presently heated with electric baseboards and also having electric hot water heaters. These homes often have an existing conventional fireplace located as a focal point in a major living area, which is ideal as a means to back out a lot of electric heat, without the high cost of a distribution system.

4. There is a dramatic range in seasonal efficiencies for gas-fired fireplaces, based on the CGA P4 standard. At this point **direct vent gas fireplaces** with pyro-ceramic glass doors, intermittent ignition and insulated casing are **the preferred units** which should be considered for efficient energy use and good, safe, healthy performance.
5. **Gas logs and vent-free gas fireplaces should not be installed in today's Canadian housing**.
6. For the advanced combustion wood fireplaces and direct vent fireplaces to reach their energy potential, they should be **properly sized and installed in a major living area**, with heat access to other parts of the house.
7. Decreasing heat loads with new housing technology are creating the potential for a **new generation of fireplace**, totally **integrated** into the house energy requirements, incorporating the needs for space, water, aesthetics and even ventilation with this unique energy generator.

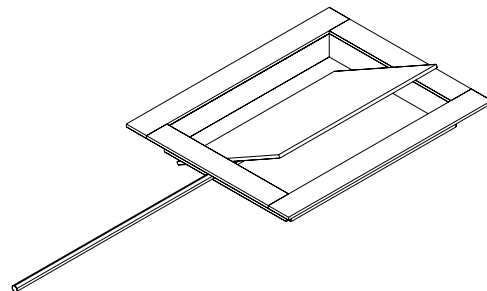

Figure 9. Outside air damper

REFERENCES & BIBLIOGRAPHY

1. Hayden, A.C.S. and Braaten, R.W.; **Efficient Residential Oil Heating Systems** - a Manual for Servicemen, Designers and Builders; SP 88-1E; Energy, Mines and Resources Canada; Ottawa, 1988.
2. Hayden, A.C.S., Braaten, R.W. and Brown, T.D.; **Oil Conservation in Home Heating**; ASME Journal of Engineering for Power, Vol. 99, Series A, No.3; July 1977.
3. Hayden, A.C.S. and Braaten, R.W.; **Effects of Firing Rate and Design on Domestic Wood Stove Performance**; Proceedings, Combustion Emissions from Solid Fuel Appliances, Air Pollution Control Association; Louisville, KY, March 1982.
4. Hayden, A.C.S. and Braaten, R.W.; **Variations in Emissions of Wood Burning Appliances Fired with Different Fuel Types**, AWMA Paper 89-95.4; Air & Waste Management Association; June 1989.
5. Barnett, S.G. and Roholt, R.; **In-Home Performance of Advanced Technology Woodstoves during the 1988-89 Heating Season in Glens Falls, New York**; AWMA Paper 90-80.6; Air & Waste Management Association Annual Meeting; Pittsburgh, PA, June 1990.
6. Barnett, S.G. and Hayden A.C.S.; **In-Home Evaluation of Emission Characteristics of High Technology Non-Catalytic Woodstoves**; Final Report on Contract 23440-9-9230/01-SQ; June 1990.
7. Hayden, A.C.S.; **Residential Combustion Appliances - Venting and Indoor Air Quality**; Environmental Progress, V.7N.4, pp 257-261; November 1988.
8. Hayden, A.C.S. and Braaten, R.W.; **Retrofitting Residential Heating Systems to Improve Efficiency and Reduce Emissions**; AWMA Paper 91-64.2; Annual Meeting, Air & Waste Management Association; Vancouver, June 1991.
9. Macintyre, K.R.; **A Creative Approach to Efficiency Testing and Efficiency Rating of Gas Fireplaces**; AWMA Paper 94-FA150.03; Annual Meeting, Air & Waste Management Association; Cincinnati, OH, June 1994.
10. Senf, Norbert; **Recent Laboratory and Field Testing of Masonry Heater and Masonry Fireplace Emissions**; AWMA Paper A99; Annual Meeting, Air & Waste Management Association; Cincinnati, OH, June 1994.
11. Hayden, A.C.S.; **Fireplaces: Studies in Contrasts**; pp 27-35, Hone Energy Magazine, September-October, 1994
12. Hayden, A.C.S. and Braaten, R.W.; **Retrofitting Residential Heating Systems to Improve Efficiency and Reduce Emissions**; AWMA Paper 91-64.2; Annual Meeting, Air & Waste Management Association; Vancouver, June 1991.

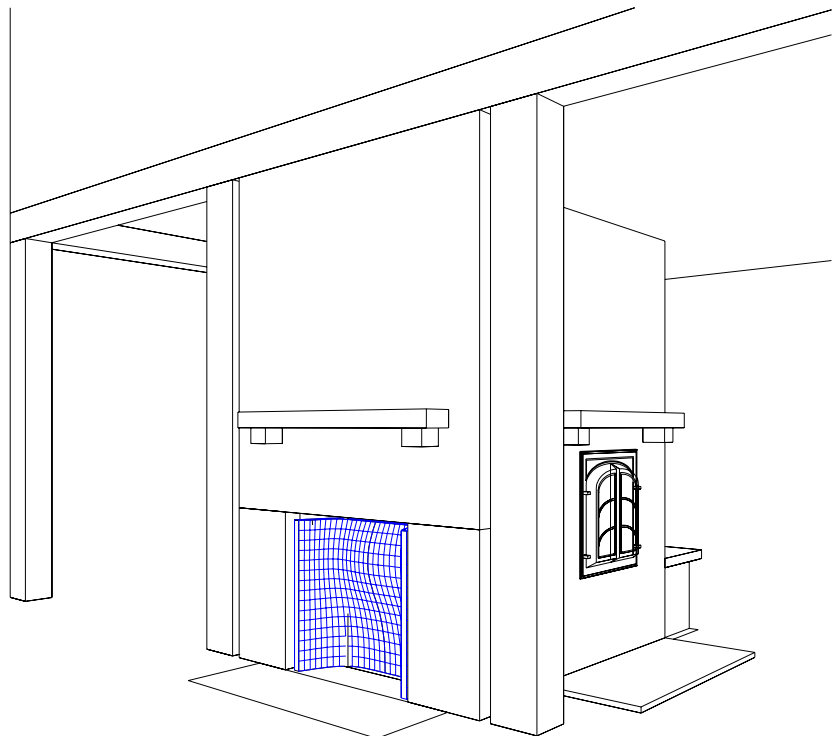
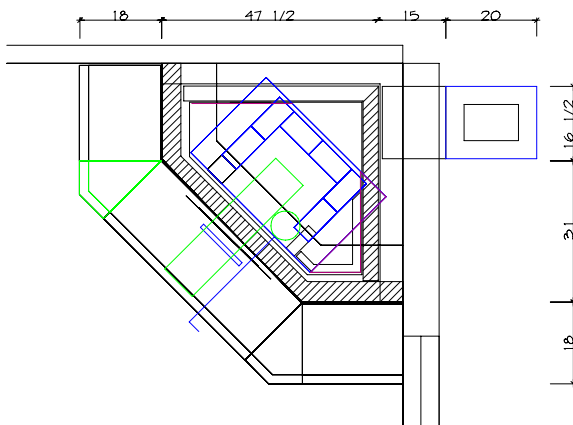

Table I. FACTORS AFFECTING FURNACE PERFORMANCE.

Demand Factors (House)		Performance Factors (Heating System)
Heat Requirements	Heat Losses	
- Thermostat	- Transmission - Infiltration - Downtime Losses	- Steady State Efficiency - Transient Operation - Dilution Air - Combustion Efficiency
SEASONAL EFFICIENCY		

Table II. Air Demands for Residential Combustion Appliances.

APPLIANCE	AIR REQUIREMENTS	
	m ³ /h	Air Changes/h
Conventional Oil	260	.52
High Efficiency Oil	37	.07
Conventional Gas	194	.39
Condensing Gas	29	.06
Conventional Fireplace	680	1.4
Advanced Wood Stove	17	.03
Advanced Fireplace	23	.04



Design and Operating Factors Which Affect Emissions from Residential Wood-Fired Heaters: Review and Update

Paul E. Tieg

with high acidity persistence (i.e., buffering) due to organic acids (2).

Subsequent to the major increases in RWH use in the early 1980s and the evolution of widespread woodsmoke pollutant problems, the RWH industry embarked on the development of low emissions technologies. The industry's fast response to the developing problems produced RWHs that emitted 60 to 80% less emissions, under laboratory test conditions, than the original "conventional" RWHs sold and in use during the early 1980s. These were the first reduced-emission woodstoves which qualified for the first state-wide woodstove certification programs promulgated by Oregon and Colorado. In 1987, the U.S. Environmental Protection Agency (EPA) promulgated an even more

RESIDENTIAL WOOD-FIRED HEATERS (RWH) HAVE LONG BEEN KNOWN TO BE SIGNIFICANT POLLUTERS, ESPECIALLY IN THE CATEGORY OF PM10 -LOADING TO LOCALIZED AIRSHEDS. IN MANY WESTERN VALLEY AREAS OF THE UNITED STATES, WOODSTOVE-GENERATED PARTICULATE AND CARBON MONOXIDE ARE MAJOR COMPONENTS OF WINTERTIME NATIONAL AMBIENT AIR QUALITY STANDARDS (NAAQS) VIOLATIONS

OMNI Environmental Services, Inc.
5465 SW Western Avenue, Suite M
Beaverton, Oregon 97005

Air and Waste Management Association
June 22, 1995
San Antonio, Texas

INTRODUCTION

Residential wood-fired heaters (RWH) have long been known to be significant polluters, especially in the category of PM10 -loading to localized airsheds. In many western valley areas of the United States, woodstove-generated particulate and carbon monoxide are major components of wintertime National Ambient Air Quality Standards (NAAQS) violations. Excessive woodsmoke loading to local airsheds also causes nuisance odors and degrades visibility and vista values.

The physical and chemical characteristics of RWH emissions has further accentuated problems in this source category. RWH generated particulates are virtually all submicron-sized organic condensate materials. In addition, several of the organic compounds found in woodsmoke have demonstrated carcinogenic and mutagenic properties (1). A 1986 study by OMNI also showed stove emissions to be highly acidic (pH 2.5 to 3.8),

stringent 2-stage, national standard for the reduction RWH emissions. This New Source Performance Standard (NSPS, 40 CFR Part 60, Subpart AAA), mandated that RWH appliances manufactured after 1990, have laboratory-tested emission reductions that represent more than an 80% reduction from the conventional woodstoves of the early 1980s.

The RWH manufacturing industry responded anew with appliances that generated even lower emissions. RWHs that were built and sold in the early 1980s generated laboratory-tested particulate emission factors ranging from 30 to 60 grams per kilogram (g/kg) of dry fuel burned. They are now being replaced by models which generate less than 7.5 g/kg (at weighted-average dry burn rates of about 1.4 kilogram per hour).

This paper reviews known operating factors which affect wood-fired heater emissions with updated test results and analyses of new technology design concepts. Batch-loaded cordwood, as well as processed wood-pellet parameters are analyzed. A review of batch-load versus air-to-fuel-mixture controlled technologies and reporting units are included in the main body of this discussion paper.

All values reported in this paper, unless otherwise noted, were obtained at the laboratories of OMNI Environmental Services, Inc., using the Oregon Department of

Environmental Quality (ODEQ) "Standard Method for Measuring the Emissions and Efficiencies of Residential Woodstoves," June 8, 1984 edition, the methods stipulated by the 1987 EPA NSPS, or the OMNI Automated Woodstove Emissions Sampler procedures which have had EPA performance audits performed four times over the last seven years.

It is important to note that if non-standard methods and protocols are used to operate woodstoves or to measure and calculate performance and emissions parameters such as fuel loading densities and configurations, efficiency algorithms, particulate sampling systems, or laboratory altitude, there can be significant differences in results. Care should be taken when comparing data generated using

BACKGROUND

The Combustion Process

Wood-fuel combustion in a RWH involves complex chemical processes which include the pyrolysis and oxidization of volatile, semi-volatile, and solid carbonaceous components of wood fibers. As in all combustion, the burning of wood requires that the four conditions or process elements of combustion (i.e., time, temperature, turbulence, and the air-to-fuel mixture ratio) be optimized for the combustion process to take place efficiently (i.e., complete oxidation of all fuel materials).

From a process control perspective, combustion in a batch-loaded cordwood-burning RWH is made more complex than most applications by

AS IN ALL COMBUSTION, THE BURNING OF WOOD REQUIRES THAT THE FOUR CONDITIONS OR PROCESS ELEMENTS OF COMBUSTION (I.E., TIME, TEMPERATURE, TURBULENCE, AND THE AIR-TO-FUEL MIXTURE RATIO) BE OPTIMIZED FOR THE COMBUSTION PROCESS TO TAKE PLACE EFFICIENTLY (I.E., COMPLETE OXIDATION OF ALL FUEL MATERIALS).

different procedures or methods unless equivalency has been demonstrated and appropriate correction factors are applied.

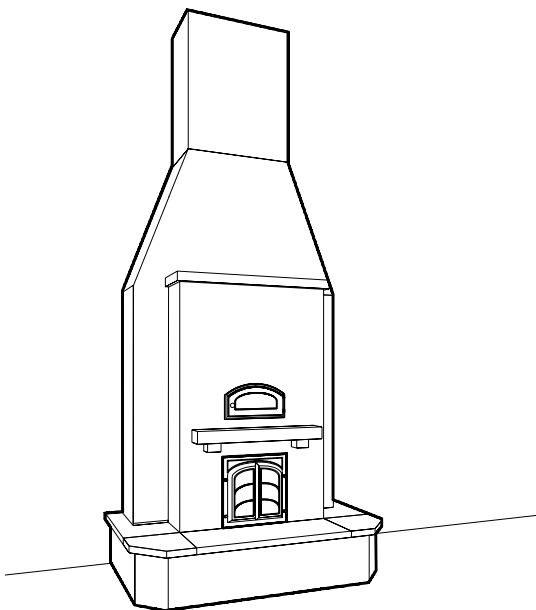

the fact that from the time a fire is first started, with paper and kindling, until the last chamber has ceased burning, all firebox conditions and combustion reactions are changing: Fuel chemistry and physical properties, fuel geometry, air supply, and temperatures, all change dramatically throughout a RWH burn cycle (i.e., the burning of a whole batch-fuel load).

Time is required to allow thorough air and fuel mixing, for energy-releasing chemical reactions, and for heat transfer to occur. If the residence time of heat-generated fuel-gases and oxygen mixing is too short, combustion will not be complete and the transfer of heat from combustion gases to stove and pipe walls will be inefficient. If residence time is too long, gas velocities in the combustion chamber are too low, and the driving mechanism for the mixing of air and fuel gases will be weak. This also leads to incomplete, inefficient combustion.

Temperature is important since the rates of the chemical reactions, which are the essence of the combustion process, increase exponentially with temperature and the driving mechanism for producing flue draft and gas flows through the whole system is dependant on heated flue gases. Generally, high temperatures in the combustion zone ensure complete combustion. In industrial gas, oil, and coal-fired systems, and in internal combustion engines, however, excessively high

combustion temperatures can also generate increased nitrogen oxides pollution. RWH combustion processes typically produce relatively low combustion zone temperatures because overall air-to-fuel ratios are more air-rich than utility or commercial boilers and because the typical RWH combustion chamber also serves as a major part of the appliance's heat exchange system. Heat therefore, is radiated and convected away from the combustion zone rather rapidly.

Turbulence is an important factor because wood-derived fuel-gases and air must mix to attain ignition and, in order to sustain the combustion process, the burning and already-burned gaseous materials must mix with fresh fuel-gases and air. Oxygen molecules must forcefully collide with

Air-to-fuel ratio is expressed as the mass of air (lb or kg) used to burn a unit mass of fuel (lb or kg). Air-to-fuel ratio is important for accomplishing efficient combustion for several reasons. In general, the overall air-to-fuel ratios in virtually all combustion applications are higher than the theoretically-exact, chemical-reactant (stoichiometric) ratios needed. A rule of thumb is that fuels that are more difficult to burn, require higher air-to-fuel ratios. For industrial boilers, the amount of excess-air (above stoichiometric) required to burn natural gas efficiently is about 5%, to burn oil about 10 to 15%, and to burn pulverized coal about 20 to 25%. These amounts represent just enough excess-air to assure that all the fuel molecules find oxygen molecules with which to react. For

TOO MUCH EXCESS-AIR IS DETRIMENTAL TO EFFICIENCY, SINCE, AS NOTED ABOVE, EXCESSIVE AIR LEADS TO LOW FLAME TEMPERATURES AND INEFFICIENT OXIDATION OF THE FUEL; THAT IS, THE "COMBUSTION EFFICIENCY" IS AFFECTED. COMBUSTION EFFICIENCY IS A MEASURE OF THE COMPLETENESS OF THE COMBUSTION PROCESS OR THE CONVERSION OF THE AVAILABLE CHEMICAL ENERGY IN THE FUEL TO SENSIBLE HEAT IN THE FIREBOX.

fuel molecules to have heat-releasing chemical reactions in combustible mixtures take place. The frequency of molecular collisions and the force of collision are both governed by temperatures and turbulence. Nearly all industrial combustion chambers, and many residential combustors are "mixing controlled." That is, the rate at which the mixing processes take place, controls the overall burn rate: "if it's mixed, it's burned."

In large utility and commercial boilers, mixing is aided by mechanical blowers or fans. In most RWH appliances, naturally generated "draft" is the primary driving force for mixing combustion gases and for powering air supply and exhaust systems. Natural draft occurs when negative pressures are generated by low density (buoyant), heated combustion gases in the RWH firebox and chimney. RWH natural draft is a relatively weak driving force (generally less than 0.1 inches water column [25 Pascals]) in comparison to blowers and fans and provides the most difficult process control challenges. A major challenge in RWH design is to use the smallest amount of draft so as to reduce heat (i.e., sensible stack) losses up the chimney or to incorporate a mechanical draft system which is reliable and compatible with wood combustion aesthetics and objectives.

industrial wood burners, the recommended amount of excess-air is not quite as well defined, though well engineered systems are found to operate in the range of 50 to 100% excess-air. Usually, the "ideal" amount of excess-air can be identified by looking for the "knee" in a curve of carbon monoxide exhaust emissions versus air-to-fuel ratio.

Too much excess-air is detrimental to efficiency, since, as noted above, excessive air leads to low flame temperatures and inefficient oxidation of the fuel; that is, the "combustion efficiency" is affected. Combustion efficiency is a measure of the completeness of the combustion process or the conversion of the available chemical energy in the fuel to sensible heat in the firebox.

Too much excess-air also affects thermal efficiency, or overall efficiency, which is the percentage of the fuel chemical energy which is actually transferred to the space or medium being heated. If excess-air is too high, the increased flow rate carries a higher proportion of the liberated heat energy up the exhaust stack where it is lost. Furthermore, the higher-than-needed flows reduce residence time and reduce the time available for heat transfer to take place. Heat transfer potential of these gases is also reduced because the heat content and hence temperature of the combustion gases is diluted by the non-essential excess-air. Thus, good

combustion design requires using only as much excess-air as is necessary.

Although all industrial and residential boilers operate air-rich, small localized pockets of fuel-richness unavoidably occur. These pockets are characterized by the production of carbon monoxide and the formation of solid and condensed aerosols. Flames in these regions usually exhibit an orange color due to thermal radiation from the aerosols. If the flame is well mixed, and thus well aerated throughout, its burning gases will appear blue in color. Sometimes the blue color is difficult to see, however, because it is overwhelmed by red-to-orange thermal radiation emanating from the hot aerosols.

REPORTING UNITS FOR RWH EMISSIONS

One significant difficulty which emerged early in the efforts to develop RWH emissions control and reduction regulations and which has also caused some controversy and confusion over the last 15 years, is the units for expressing the amount of emissions from RWH appliances. The two primary reporting-unit candidates considered since the regulation of RWH emissions began in the early 1980s, are:

- 1) The emission factor; i.e., how much (mass) of pollution is discharged per mass of fuel burned, expressed in grams per kilogram (g/kg), and
- 2) The emission rate; i.e., how much (mass) of pollution is discharged per unit of time,

EVEN THOUGH CONVENTIONAL, NATURALLY DRAFTED RWHs USUALLY OPERATE VERY AIR-RICH, BECAUSE OF POOR MIXING, MOST OF THE EXCESS-AIR NEVER BECOMES INTIMATELY MIXED WITH THE FUEL GASES. THUS THE FLAME IS YELLOW IN APPEARANCE AND CONTAINS LARGE AMOUNTS OF SOLID CARBON AND UNBURNED CONDENSATE AEROSOLS. EVEN IF THE EXCESS-AIR DOES BECOME MIXED WITH THE OTHER GASES, THE RESULTING AIR-RICH MIXTURE IS FREQUENTLY TOO COOL TO ALLOW COMPLETED REACTIONS.

Even though conventional, naturally drafted RWHs usually operate very air-rich, because of poor mixing, most of the excess-air never becomes intimately mixed with the fuel gases. Thus the flame is yellow in appearance and contains large amounts of solid carbon and unburned condensate aerosols. Even if the excess-air does become mixed with the other gases, the resulting air-rich mixture is frequently too cool to allow completed reactions.

In order for fuel to burn in a RWH, the design and operation has to address the four elements of combustion discussed above. The extent to which all of these elements are optimized throughout a RWH burn cycle governs the efficiency and emission characteristics of the RWH.

expressed in grams per hour (g/hr).

A third candidate, mass of pollution discharged per unit of useful room heat produced by an a RWH appliance expressed as grains per British thermal unit (gr/Btu, or in SI units; grams per Megajoule (g/MJ)) had been considered in the early days of regulation development. However, because a verified method for measuring efficiency did not exist at that time and it was thought that an acceptable and accurate measurement method would be very expensive, this unit of measure never gained favor by regulators or the RWH appliance manufacturing industry.

The basis for controversy between using either of the two primary-candidate reporting units is whether one or the other provides better information for ranking one RWH appliance against another and/or whether one or the other provides better and more useable information for modelling the relationship between the amount of RWH pollution being discharged into an airshed and how the RWHs are being operated. It would be simplified and ideal if RWH appliances discharged pollutants at constant rates or even consistent rates for any given burn rate

or heat output level. The only RWH appliances which can emit pollutants at close to constant rates are the pellet stoves. Pellet stoves and other residential heating appliances, like oil or gas furnaces and most large combustion sources like electric power utility boilers, have controlled air supplies and fueling rates to optimize combustion processes at or near a "steady state"

conditions. Having the ability to operate at optimized steady-state conditions can maintain nearly constant, low-pollutant emission rates over long periods of time.

If cordwood-burning RWH appliances had steady-state combustion conditions and constant and consistent emissions rates, relatively simple

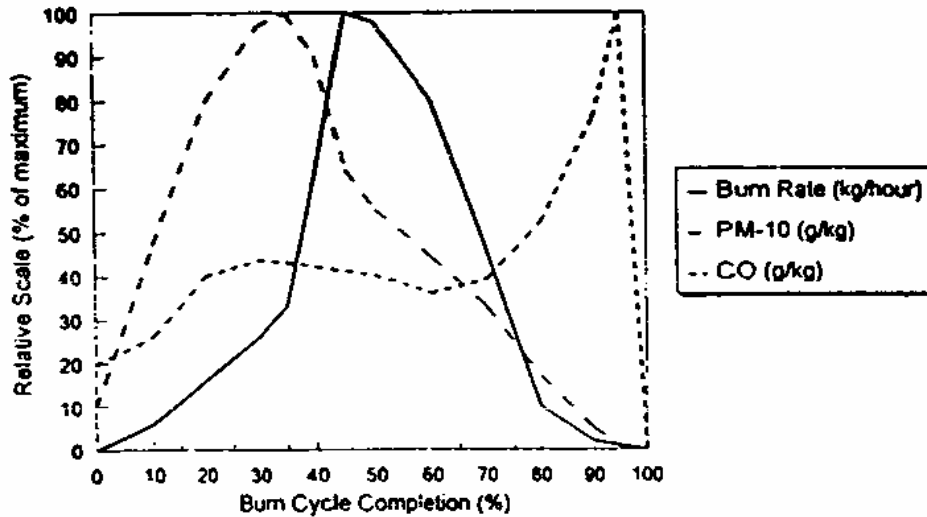

Figure 1 Gram per kilogram (g/kg) emissions versus burn cycle completion.

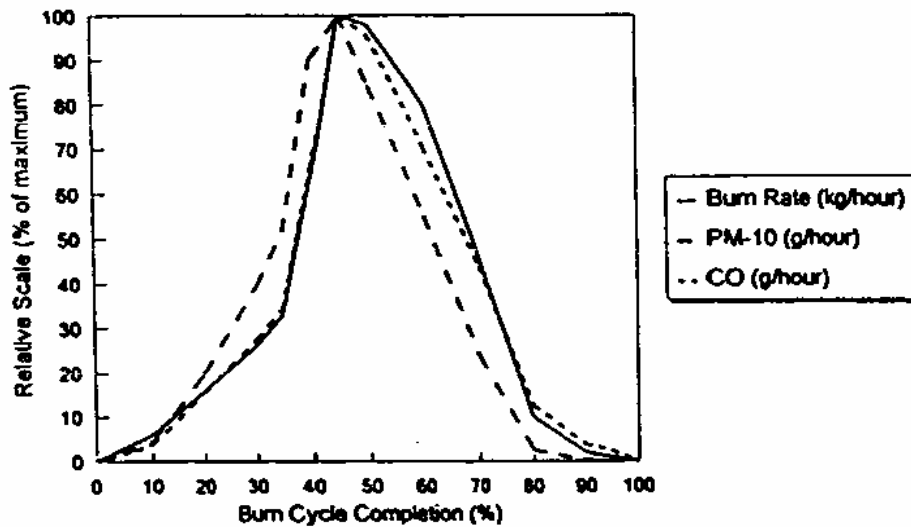

Figure 2. Gram per hour emissions versus burn cycle completion.

calculations could be used for developing good estimates or models of airshed pollutant loading caused by RWH appliances. But the fact is that

no RWH appliances, except pellet stoves, discharge pollution at a constant rate from the beginning to the end of a complete burn cycle or even consistent rates from one burn-rate/heat-output level to the next. As mentioned earlier, during the burn cycle of a cordwood-fuel load in an RWH appliance, its physical and chemical

characteristics change dramatically as do the amount and the physical and chemical nature of the pollutants being produced and discharged. Everything is always changing in a cordwood-burning RWH appliance including combustion-influencing parameters like temperatures, fuel weight, and fuel-load geometry.

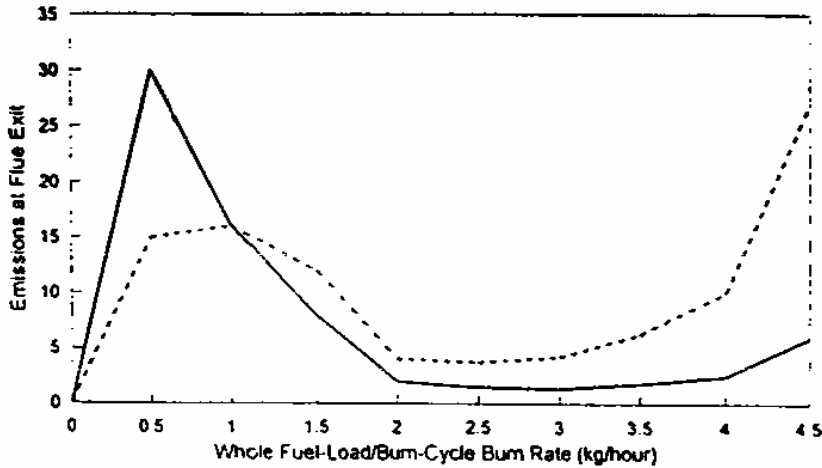

Figure 3. Gram per hour (g/hr) and gram per kilogram (g/kg) PM-10 emissions versus full fuel-load/burn-cycle burn rate.

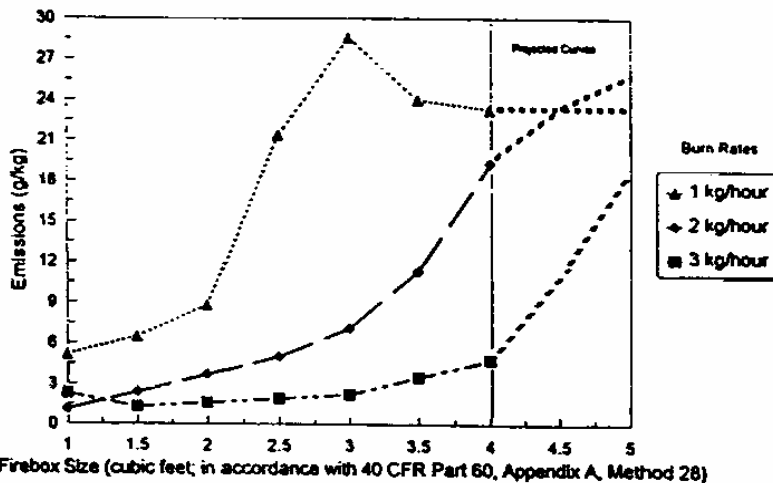

Figure 4. Firebox volume (fuel-load size) versus g/kg-emission factors for three whole-fuel-load/burn-cycle rates. All fuel loading densities were at or near 7 pounds per cubic-foot of firebox volume.

Analysis of Cordwood-Burning RWH Emissions Dynamics

Figure 1 is a generalized illustration showing how particulate and carbon monoxide emission factors (g/kg) change as well as how the burn rate itself changes as one, full cordwood fuel load is burned (i.e., one "burn cycle") and the RWH appliance is operated at one air supply setting. A percentage (relative) scale is used on the "y" axis to show the maximum for each graphed parameter. This illustration demonstrates how each parameter changes relative to the minimums and maximums of the other graphed parameters.

The fuel load is ignited at 0% fuel-load consumption. The burn rate begins slow at this point but increases rapidly to a maximum fuel consumption rate (i.e., kg/hr) at a point when about 50% of the fuel weight has been consumed. This is also the time when the greatest amounts of volatile and semi-volatile materials (i.e., fuel-gases) are being driven from the solid wood fuel. Emission factors (g/kg) for both particulate and CO emissions begin rising right at the point the fuel is ignited. At the beginning of a burn cycle, particulate emission factors (g/kg) increase more rapidly than the emission rate (g/hr), however, as volatile and semi-volatile materials in the fuel load are heated and vaporized by the increasing amount of heat being generated.

Because all RWH appliances, except for pellet stoves, are batch-loaded fuel processors and rely on very weak, naturally drafted air supplies, it is unavoidable that periods of time will occur during a burn cycle when at least a portion of the combustion zone will have un-optimized, imperfect combustion conditions (e.g., not enough oxygen, residence time, or the mixing and/or temperature conditions are not optimum). State-of-the-art, low-emission RWH appliances optimize the average combustion conditions of the burn cycle using combustion-air distribution systems which are powered by natural draft forces. They also use enhanced firebox heat management designs for optimized average thermal performance. But, even with this "new" technology, it is impossible without expensive auxiliary (e.g., electrically) powered control designs to avoid all imperfect combustion conditions that can occur with a batch-loaded process. It is the unburned or incompletely burned volatile and semi-volatile materials

resulting from these imperfect combustion conditions that escape the firebox and form particulate emissions as they cool and condense on their way up the chimney.

Analyzing Figure 1 further shows that after the particulate emission factors (g/kg) are maximum at a point when about 30% of the fuel load has been consumed, they decrease due to improving, more vigorous combustion conditions in the firebox (i.e., higher temperatures and more mixing). Particulate emission factors (g/kg) then decrease further after about 60% of the fuel load is consumed due to decreasing volatile and semi-volatile contents of the fuel. The stage of the burn cycle after which the volatile and semi-volatile contents of the fuel have been depleted is sometimes called the charcoal stage of a burn cycle and is characterized by low particulate emissions.

Like particulate emission factors (g/kg), CO emission factors (g/kg) increase in the early stages of the fire due to the increasing amount of fuel being burned with inadequate temperature and/or mixing conditions. CO emissions per kilogram of fuel being burned (g/kg) start decreasing after about 40% of the fuel is consumed which is when combustion conditions begin to improve. CO emission factors (g/kg) decrease slowly until a point at which the burning fuel is dominated by coals (which is characterized by both high carbon and low volatile and semi-volatile material content). At this point, there is usually sufficient temperature for good combustion. However, inadequate air and fuel mixing becomes the dominant combustion imperfection which causes the dramatic increase in the amount of CO produced for every kilogram of fuel burned at this final part of the burn cycle.

Figure 2 has similar axis scales to those in Figure 1 except that Figure 2 shows how particulate and CO emission rates (g/hr) change during a burn cycle and, as in Figure 1, it includes a curve showing how the burn rate itself changes during one full fuel-load burn cycle at a constant air supply setting. Since the emission rates are a direct function of burn rate,

i.e., burn rate (kg/hr) x emission factor (g/kg) = g/hr,

changes in both the particulate and CO emission-rate curves follow changes in the burn-rate curve very closely. This emission-rate graph (gr/hr) shows clearly that at the same time in the burn cycle when large changes in the amount of emissions being produced for every kilogram of

cordwood-burning RWH appliance delivering the same total amount of useful heat.

Figure 3 is a laboratory data graph that shows how both the PM₁₀-particulate emission rate (g/hr) and emission factor (g/kg) values change as full fuel-load burn-cycle burn rates change in a typical non-catalytic RWH appliance.

Although the data used in Figure 3 are from non-

MASONRY HEATERS ARE ALL DESIGNED TO BURN FUEL AT ONE BURN RATE IN THE MID- TO HIGH-COMBUSTION-OPTIMIZED RANGE TO OBTAIN THE MOST HEAT PRODUCTION AND LOWEST EMISSIONS POSSIBLE. THE WHOLE CURVE FOR A MASONRY HEATER WOULD BE ONE POINT OR WOULD ONLY COVER A SMALL SEGMENT IN THE COMBUSTION-OPTIMIZED SEGMENT OF THE BURN-RATE RANGE. THIS IS BECAUSE MASONRY HEATERS ARE ONLY DESIGNED TO HAVE ONE BURN RATE. IF A MASONRY HEATER FIREBOX IS DESIGNED POORLY, THE G/KG-CURVE (POINT) WOULD BE HIGHER IN THIS COMBUSTION-OPTIMIZED PART OF THE CURVE AND THE CURVE (I.E., POINT) WOULD BE LOWER IN A WELL DESIGNED MASONRY HEATER. WELL DESIGNED PELLET STOVES ON THE OTHER HAD WOULD HAVE A CONSTANT, FLAT, NO-SLOPE, CURVE ALL THE WAY ACROSS THE WHOLE RANGE OF BURN RATES.

fuel being burned are taking place (as shown in Figure 1), there is little evidence of whether combustion conditions are improving or deteriorating. Figure 2 is useful however, for showing that increasing fuel consumption rates do increase both CO and particulate emissions rates (g/hr).

Figure 2 (the gram per hour curves) also illustrates how good combustion conditions, and hence, low emissions per kilogram of fuel being burned can be masked by a high burn rate: i.e., lower g/kg emissions and optimum combustion conditions occur at the relatively higher burn rates but are not indicated by the g/hr curves. This is ironic because it is at the higher burn rates that the batch-loaded cordwood-burning RWH appliances universally have the best combustion conditions and the lowest amount of emissions per kilogram of fuel being burned. This also means that a good cordwood-burning RWH appliance design can consistently produce the best optimized combustion conditions but because it may have consistently high burn rates, and hence, more heat output, it can be kept from the market because of high g/hr emissions. With equal overall efficiencies and equal g/hr emission rates, a high burn-rate cordwood-burning RWH appliance would discharge less pollution to the atmosphere than a low burn-rate

certified stoves, the patterns shown are characteristic of all cordwood-burning non-catalytic RWH appliances with adjustable air supplies and hence, adjustable burn rates. Each data point in each curve represents a whole fuel-load burn cycle at one air supply setting. Therefore, it takes many tests to gather the data for these curves. The size of any particular stove (and hence its fuel-load size) will shift the kilogram-per-hour burn rate scale right or left but the resultant emission rate and emission factor patterns will stay the same. Even poorly designed woodstoves would have the same patterns but the scale for emissions rates and emission factors on the "y" axis would increase to show higher emissions at any given burn rate.

The emission rate (g/hr) curve in Figure 3 shows rapidly increasing emissions as burn rates increase in the very lowest burn-rate range below 0.4 kg/hr, followed by a continuing, although lower-slope increase to the 1.0 kg burn-rate level. The g/hr then shows a decrease as the burn rate increases in the mid-ranges to 2.0 kg/hr. The rapidly rising g/hr emissions that occur when the burn rate increases in the lowest burn-rate range below 0.4 kg/hr, are due to large relative increases in burn rate with concurrently increasing emissions reaching the atmosphere for each kilogram of fuel being burned. There is an

increase in emissions discharged to the atmosphere as burn rates increase at these very low burn rates in spite of the fact that air/fuel mixing is improving and higher temperatures are being generated. This is because at the very lowest burn rates (i.e., less than 0.4 kg/hr on this

example, if there is a doubling of the burn rate from 0.5 kg/hr to 1.0 kg/hr and at the same time there is a 35% decrease in emissions produced by each kilogram of fuel being burned, the g/hr emission rate still increases 30%. That is,

0.5 kg/hr burn rate x 30 g/kg emission factor =

THE USE OF G/HR UNITS STARTED IN OREGON AND THEN WAS ADOPTED BY COLORADO AND FINALLY BY EPA. DURING THE NSPS NEGOTIATIONS, THERE WAS EPA RESISTANCE TO CHANGE FROM THE UNITS USED BY OREGON AND COLORADO EVEN WITH SOLID TECHNICAL ARGUMENTS SUPPORTING CHANGE. THE RECORD OF EPA'S NEW SOURCE PERFORMANCE STANDARD (NSPS) NEGOTIATIONS WITH THE RWH APPLIANCE MANUFACTURING INDUSTRY CLEARLY SHOWS THAT THE CHOICE FOR G/HR WAS NOT MADE WITHOUT CHALLENGING COMMENTS OR GOOD ALTERNATIVE RECOMMENDATIONS. EPA ARGUED THAT SINCE THEIR GOAL WAS ONLY TO DEVELOP A RELIABLE RANKING SYSTEM FOR COMPARING REGULATED RWH APPLIANCES TO ONE ANOTHER, THE ALREADY-USED G/HR UNITS WOULD BE CHOSEN.

graph) where the worst combustion conditions occur and the maximum amount of emissions are produced in the combustion zone for every kilogram of fuel burned, some of the emissions condense and get deposited on firebox and flue pipe walls before they can be discharged to the atmosphere. This phenomenon actually results in lower emissions to the atmosphere but a higher rate of creosote deposition in the chimney. Although always present in these low burn-rate ranges, the effect of flue-pipe creosote deposition on emissions discharged to the atmosphere decreases as the burn rates increase from about 0.5 kg/hour.

The emission-factor (g/kg) curve also increases in the burn rate range below 0.4 kg/hr. Since g/kg does not have a direct mathematical relation with burn rate like the g/hr units, the increase in emissions in this burn rate range is due only to the decreasing effect of creosote deposition as the burn rate increases.

The g/kg curve decreases after the 0.4 kg/hr burn rate because the effect of better air/fuel mixing and higher temperatures decrease the amount of emissions being produced for every kilogram of fuel being burned. Although the amount of emissions per kilogram of fuel being burned decreases, the g/hr curve continues to increase above the 0.4 kg/hr burn rate due to the fact that the large relative increase in burn rate offsets the relative decrease in the amount of emissions produced for each kg of fuel burned. For

15 g/hr emission rate,

then doubling the burn rate and decreasing the emission factor by 35% gives:

1.0 kg/hr burn rate x 19.5 g/kg emission factor = 19.5 g/hr emission rate,

which is a $((19.5-15.0)/15.0) \times 100 = 30\%$ increase in the emissions rate when combustion and heat delivery conditions are actually improving.

By definition and by their direct mathematical relationship, the g/hr- and g/kg-curves cross at the 1.0 kg/hr burn rate. After these curves cross, the decreasing g/kg emissions overcome the relative increases in burn rate which then effect a decrease in the g/hr-curve. As the burn rate approaches 2.0 kg/hr the g/kg emissions decrease to a minimum due to optimized combustion conditions in the firebox. The height of the g/kg-curve at the point that combustion (or more appropriately, the quality of the burn) is optimized is a function of firebox/stove design. Better designs will have lower g/kg-curves in the combustion-optimization range.

An important fact about this part of the g/kg-curve is that the combustion-optimization segment of the curve covers a relatively large area of the mid- to high-burn-rate range and not the low burn- rate ranges. All EPA certified non-catalytic cordwood-burning RWHs must burn a large portion of each fuel loading within

this range or they will not have a low emissions rate (i.e., g/hr). It is important to note again that even if the quality of the combustion process (i.e., g/kg) stays the same from one burn rate to the next in these stoves, just increasing the burn rate would increase their g/hr emissions rate. It is also important to note this low emission factor part of the g/kg curve because this is the burn-rate range where Colorado- approved masonry heaters always operate. This is also true for pellet-fired RWHs, however, instead of having one (high) burn rate in the optimized g/kg burn-rate range, pellet-fired RWHs adjust their fueling and combustion-air delivery rates to maintain the same relative fuel-load (burnpot) consumption rate.

Masonry heaters are all designed to burn fuel at one burn rate in the mid- to high-combustion-optimized range to obtain the most heat production and lowest emissions possible. The whole curve for a masonry heater would be one point or would only cover a small segment in the combustion-optimized segment of the burn-rate range. This is because masonry heaters are only designed to have one burn rate. If a masonry heater firebox is designed poorly, the g/kg-curve (point) would be higher in this combustion-optimized part of the curve and the curve (i.e., point) would be lower in a well designed masonry heater. Well designed pellet stoves on the other hand would have a constant, flat, no-slope, curve all the way across the whole range of burn rates.

Again, by definition and because of the direct mathematical relationship between g/hr and g/kg, the g/hr-curve increases throughout the combustion-optimized segment of the burn-rate range. This is due to the fact that although the g/kg curve is constant (flat) showing no change in the quality and efficiency of the combustion process taking place in this burn-rate range, merely increasing the burn rate causes the g/hr-curve to increase. For example, keeping the g/kg emission factor constant while the burn rate changes from 2.5 to 4.0 kg/hr will increase the g/hr emission rate by 60%. That is,

5.5 g/kg emission factor x 2.5 kg/hr burn rate = 13.75 g/hr emission rate,

then increasing the burn rate from 2.5 to 4.0 kg/hr gives;

5.5 g/kg emission factor x 4.0 kg/hr burn rate = 22.00 g/hr emission rate,

which is a $((22.00-13.75)/13.75) \times 100 = 60\%$ increase in the emission rate.

Therefore, it can be very misleading to assess the pollution characteristics of a cordwood-

burning RWH appliance, by only using a g/hr value. Any clean burning appliance design can have high g/hr emission rates just because it can be made to burn fuel fast. Even though they can be producing more heat with lower total emissions to the atmosphere, single, high burn-rate appliances such as masonry heaters are unfairly viewed by some regulators as high polluters when g/hr values are used for comparison to other types of appliances like adjustable burn-rate RWHs.

To conclude the g/hr- and g/kg-curve analysis, the increase in g/kg emissions at burn rates above 4.0 kg/hr is due to decreasing combustion efficiency which is caused, in most cases, by excess combustion-air cooling or by dilution of the combustible fuel-gases given off by the heated wood before they can burn. Depending on the firebox design, the fire can also become too fuel-gas rich because too much of the fuel load is being heated to high temperatures too quickly which creates large amounts of combustible fuel-gases without enough air for efficient combustion. In either of these cases the amount of pollution created by each kilogram of fuel increases and hence, the slope of the g/hr-curve increases even more. The g/hr-curve increase progresses at a steeper slope than the g/kg-curve because it is compounded by both an increasing burn rate and an increasing emission factor.

To get around the problems presented by the variable and constantly changing cordwood-burning RWH combustion and emissions parameters, the EPA and the Oregon and Colorado state certification testing programs, required that regulated RWH appliances be tested for emissions at four different burn rates ranging from low to high. Since each certification test-run emissions sample is taken/collected over an entire burn cycle, each test represents the average pollutant discharge that took place during the burning period for each of the four whole fuel loads. The results from each of the four separate tests are then weight-averaged together using weighing factors derived from the expected average annual residential heat demand of the average house in an average heat demand location in the U.S. (i.e.,

about 17,000 Btu/hour). Therefore, at the end of this certification process there is a single emission rate (in g/hr as required by EPA) for each model of regulated RWH appliance. This emission rate indicates the average mass of pollution that can be expected to be discharged on an hourly basis when the appliance is in operation.

It is important to note in this discussion that the g/hr and g/kg units are both resultant data from certification testing of RWH appliances. No additional testing is required to obtain either reporting unit. It's only a quirk of history that of the three options for reporting units, the EPA, and the states that have had certification programs, chose the g/hr units to establish

above, the heat output-based emission-rate units were not used since they would require the measurement of overall thermal efficiency and EPA felt the thermal efficiency measurement methods available at the time the NSPS was being negotiated were costly and not verified enough to use in EPA's certification program.

A very important point to note is that in all of the codified test methods for determining grams per hour (g/hr) reporting units for regulating RWH appliances, it is not required that the appliances being tested provide any useful space heating.

All that is needed to determine g/hr is the measurement of total exhaust-gas flow rate and the pollutant concentration; i.e.,

$$\text{g/m}^3 \times \text{m}^3/\text{hr} = \text{g/hr.}$$

A VERY IMPORTANT POINT TO NOTE IS THAT IN ALL OF THE CODIFIED TEST METHODS FOR DETERMINING GRAMS PER HOUR (G/HR) REPORTING UNITS FOR REGULATING RWH APPLIANCES, IT IS NOT REQUIRED THAT THE APPLIANCES BEING TESTED PROVIDE ANY USEFUL SPACE HEATING.

regulatory emission limits for RWH appliances.

The use of g/hr units started in Oregon and then was adopted by Colorado and finally by EPA. During the NSPS negotiations, there was EPA resistance to change from the units used by Oregon and Colorado even with solid technical arguments supporting change. The record of EPA's New Source Performance Standard (NSPS) negotiations with the RWH appliance manufacturing industry clearly shows that the choice for g/hr was not made without challenging comments or good alternative recommendations. EPA argued that since their goal was only to develop a reliable ranking system for comparing regulated RWH appliances to one another, the already-used g/hr units would be chosen.

Clearly the most useful reporting units would have been in grams of pollutants discharged to the airshed per unit of useful heat output from the RWH appliance. The real advantage of this unit-of-measure is that it would take into account the overall thermal (both combustion and heat transfer) efficiency of the appliance. If the g/hr and/or g/kg test results indicated that two RWH appliance models had equal emissions, the more efficient model would burn less fuel to heat the same space, and hence, emit less pollution to the airshed. As mentioned

Where: g/m^3 = grams of emissions per cubic meter of flue gas.

m^3/hr = cubic meters of flue gas flow per hour.

Neither the concept of g/hr itself nor the test method protocols to measure g/hr emissions, require the production of any useful heat, only that the appliance be able to burn specified fuel loads within 4 prescribed burn rate categories. To emphasize: The test methods do not use heat output categories, just burn rate categories.

During the New Source Performance Standards (NSPS) negotiations in 1986, EPA decided to assume standard thermal efficiency levels for all regulated RWH appliances. Considering their objectives, this approach to efficiency is somewhat reasonable since the definition of the appliances being regulated (EPA calls them "affected facilities") imposes physical and operating specifications like air-to-fuel ratio, weight, and firebox volume limitations which when used in combination with the required burn rate categories and the emission limits, result in the approximate EPA-assumed efficiency levels. This is not just coincidental but an engineering fact that if all the affected-facility definition criteria, test-protocol requirements, and emission limits are met, the overall thermal efficiency

levels of the regulated RWHs will be close to EPA's assumed levels.¹

Most importantly, when discussing units of measure, the unique features of the EPA regulated RWH appliances (e.g., not including masonry heaters) that make the g/hr units useable in the regulation of these emissions are:

- 1) The heat output (burn rate) of the appliance is adjustable on a real time basis. If the user desires more heat, the air supply and/or fuel load is increased to increase the combustion process and if less heat is desired the air and/or fuel load is decreased, and
- 2) The production of heat in the firebox by the fuel-burning combustion process and the release of that heat to the surrounding space

only because these features are unique to the regulated RWHs. This does not mean that g/kg or the mass of emissions per unit of useful heat output (e.g., g/MJ) could not be used or even be useful. In fact, either one of these reporting units could be used with at least as much and definitely more useful information being provided about the quality and efficiency of the combustion process taking place. No other appliances or EPA-regulated source types burning any other fuel for any other purposes can reasonably use the g/hr unit alone. No matter what the source, without production or process throughput data there is always serious potential for communicating incorrect information.

It is only the design specifications imposed by

NO OTHER APPLIANCES OR EPA-REGULATED SOURCE TYPES BURNING ANY OTHER FUEL FOR ANY OTHER PURPOSES CAN REASONABLY USE THE G/HR UNIT ALONE. NO MATTER WHAT THE SOURCE, WITHOUT PROCESS THROUGHPUT DATA THERE IS ALWAYS SERIOUS POTENTIAL FOR COMMUNICATING INCORRECT INFORMATION. IT IS ONLY THE DESIGN SPECIFICATIONS IMPOSED BY EPA'S NSPS WOODSTOVE (AFFECTED-FACILITY) DEFINITION IN COMBINATION WITH THE EMISSION LIMITS IMPOSED ON THE REGULATED RWHs THAT ALLOW THE USE OF G/HR UNITS.

occurs at virtually the same time. There is no, or only a very small delay between heat production by the fuel-burning process and the transfer of that heat to the space being heated. RWH appliance firebox shells are virtually all made from either sheet metal or cast iron to accommodate this heat transfer. In either case, these high heat-conducting materials are used because they "transfer" heat from the firebox to the surrounding space as quickly as possible. Because the regulated RWHs are not designed for heat storage, there is no (or only very little) storage of heat in the mass of the appliance. Regulated RWH appliances make heat in the firebox and transfer it to the space being heated as soon as possible.

These features allow the g/hr unit of measure to be applied to regulated RWHs, but applicable

EPA's NSPS woodstove (affected-facility) definition in combination with the emission limits imposed on the regulated RWHs that allow the use of g/hr units. In addition, because of the definition and the emission limitations, regulated RWHs are, actually by default, regulated based on the amount of emissions produced per unit of useful heat output. This is because of the assumed efficiencies and therefore the assumed amount of useful heat output generated during the burning of test fuel at the rates required by the test protocols: e.g., virtually all regulated non-catalytic stoves burning 1 kg/hr will produce approximately 12,500 Btu/hr of useful heat to the surrounding room, and virtually all catalytic stoves will produce approximately 14,500 Btu/hr when burning 1.0 kg/hr of fuel. This is because the efficiencies for all of the regulated RWH appliances within each category (i.e., non-catalytic or catalytic), are nearly the same.

Masonry heaters were intentionally excluded from EPA's NSPS by EPA's specified weight criteria (affected facilities have to be less than 800 kg). EPA rationale was that masonry heaters would require time- and money-

¹. Actually the EPA has two categories of regulated RWH appliances; catalytic and non-catalytic, and each category has its own assumed thermal efficiency for all RWH appliances in the group.

consuming development of new test method and operating protocols and most importantly because of their designed, consistent high burn-rate, would be clean burning anyway and would not present problems in local airsheds. In addition, if the EPA was to regulate masonry heaters, the reporting units for emissions would have to have been changed first.

The g/hr emission rate is not useful or appropriate for masonry heaters since masonry heaters only burn fuel during a very short part of their useful heat output cycle. In addition, if masonry heaters are to be ranked or compared to other RWHS, EPA's NSPS test-method operating protocol (Method 28, 40 CFR Part 60, Appendix A) would have to be changed. Since the primary burn-cycle mode of operation for masonry

emissions actually discharged by a regulated RWH appliance during cold startup operations.

This is not a criticism of the method, if it is kept in mind that the method was designed and adopted to rank stoves against one another and not to simulate actual and absolute in-consumer-use emission rates. It was felt by almost all of the regulators participating in the NSPS regulation negotiations, that ranking of stoves with an indicated relative emissions reduction was more important than trying to establish absolute or "real world" emission rates for certified stoves. That is, an NSPS limit of 7.5 g/hr for non-catalytic RWHS was a 75 percent reduction from the 30 g/hr which was considered by the regulators to be the emissions rate for the common "conventional" stoves in use at the time

OMNI'S DATA ON MASONRY HEATERS IS A "REAL WORLD" EMISSION RATE THAT IS NOT DIRECTLY COMPARABLE TO RWH CERTIFICATION DATA.

heaters is one fuel load burned at the full-high burn rate until all the fuel is gone, the test cycle would need to include the whole cycle including start-up and complete burn down (i.e., a "cold-to-cold" test-burn cycle). The test-method operating protocol would have to take into account the fact that useful heat output is produced by masonry heaters long after the fire has gone out.

Method 28 for woodstoves is a hot-to-hot test-burn cycle: a hot coal bed is established in a hot stove; a specified fuel load is then added to begin the test; and completion of the test is at the point in time when the added fuel is totally consumed back to the original, hot coal bed. This cycle is conducted at 4 different, and specified burn rates to make a complete certification test series.

It is important to realize the difference between testing an RWH appliance using a hot-to-hot test cycle as opposed to using a cold-to-cold test cycle. In 1986, Jay Shelton of Shelton Research in Santa Fe, New Mexico (personal communication) did a woodstove research project for the State of Colorado and found that emissions discharged during the cold start up phase of a woodstove equals 50 percent of the emissions discharged during a whole hot-to-hot test cycle. This means that the standard EPA test method misses up to 33 percent of the total

of the NSPS negotiations. The idea was that the 75 percent reduction indicated by the laboratory test method would translate to a 75 percent reduction in actual home-heating-use emissions to the atmosphere, regardless of what the actual or absolute emissions rates were. The objective was to get the 75 percent reduction. There was never any attempt or wish expressed by EPA in the NSPS negotiations to use RWH certification emissions values for estimating or modeling airshed emissions loading rates⁽³⁾.

On the other hand, therefore, it should be kept in mind that contrary to the woodstove test protocol of hot-to-hot test periods, all standardized masonry heater testing performed by OMNI to date has sampled the whole burn cycle on a cold-to-cold basis (defined by flue-gas temperatures of less than 100°F). The Automated Emission Sampler (AES) used by OMNI Environmental Services in performing 'in-situ' field and laboratory sampling of masonry heaters, collects emissions samples during all phases of the burn cycle, including start-up from cold (i.e., flue-gas temperature above 100°F) to cold, total-fuel burn-down. All fuel loads burned during the total sample period of one week or more, 24 hours a day, are sampled. Thus OMNI's data on masonry heaters is a "real world" emission rate that is not directly comparable to RWH certification data.

Secondary Combustion

Over the last 10 years, low-emission non-catalytic RWH appliances have been developed which exhibit weighted-average emissions well below the EPA NSPS - required 7.5 g/hour (approximate conversion to 5.4 g/kg). These appliances depend on fine-tuned firebox configurations and operating protocols which optimize the average, air-regulated batch-loaded-fuel combustion conditions over whole fuel-load burn cycles. Virtually all of the non-catalytic RWHs currently on the market have manual controls for setting air supplies and burn rates. One of the most notable non-catalytic RWH features is that none of them have thermostatic combustion controls. The lack of thermostatic control on non-catalytic RWHs is not some extraordinary coincidence of design. To date, no design mechanism or technology has been developed which can accommodate clean burning with the complex dynamics of batch-loaded-fuel combustion and air-supply-mediated burn rate control.

In addition, all EPA certified non-catalytic RWHs to date have utilized natural draft to drive the flow of combustion air through the combustion systems. None of the batch-loaded cordwood burning RWH appliances utilize externally powered fans for providing combustion air delivery to the combustion chamber. And, since combustion air control is the only method available for controlling the rate of combustion in batch-loaded-fuel systems, the only practical means available for modulating combustion is by the application of thermo-mechanical devices; i.e., devices which have a mechanical response to changes in temperature.

Batch-loaded non-catalytic RWHs cannot accommodate modulated air supply while maintaining clean burning conditions because

clean burning is dependant on maintaining the active high temperature combustion of fuel gases generated by the heated fuel load. When a thermostat decreases the air supply to the combustion chamber, the balance of air-to-fuel ratios and mixing turbulence is shifted which very often leads to cessation of gaseous combustion activity (i.e., flame). Under these circumstances, the unburned or incompletely burned gases leave the combustion chamber as emissions (i.e., smoke). No design factor has yet been devised for batch-loaded maintaining clean burning, efficient combustion in non-catalytic RWHs where the air supply is reduced during the combustion of a fuel load.

The typical batch-loaded non-catalytic RWH is configured with primary and secondary combustion chambers. The primary combustion chamber is sized to accommodate a cordwood fuel load and is located directly below the secondary combustion chamber. The structure separating the primary and secondary combustion chambers is typically called a baffle. The term "secondary" refers to the area or chamber where combustion of only gaseous fuel materials takes place. Typically the secondary combustion chamber is smaller than the primary combustion chamber and is constructed of materials which can contain and hold as much heat as possible so the elevated temperatures can be maintained as long as possible. Also typical is the addition of heated air to the combustion gases as they leave the primary combustion chamber and enter the secondary combustion chamber. This heated air is usually referred to as "secondary air." The size of the secondary chamber, the amount and temperature of added secondary air, and the temperatures and turbulence within the secondary combustion chamber govern the quality of secondary combustion which can take place.

If this primary and secondary combustion system is optimized for an air supply which is governed only by natural draft, it is very difficult to maintain the appropriate air-to-fuel ratio, temperature, and mixing conditions for sustaining active and clean combustion. This is especially true when the primary air supply is mechanically altered to reduce the overall combustion rate. Gaseous combustion ceases when air-to-fuel ratios drop below approximately 15:1 and when combustion gas temperatures drop below approximately 950°F. Once gaseous combustion ceases, temperatures, of course, fall rapidly and air-to-fuel ratios decrease as does turbulence which is needed for adequate mixing of the air and fuel gases.

Most catalyst equipped batch-loaded RWH appliances currently on the market, are also equipped with devices which provide thermostatic control of their combustion air supply. Thermostats utilized on these stoves are universally powered by the thermo-mechanical response of bimetallic coils. As temperatures on the surfaces or in the spaces where the bimetallic coils are placed change, the bimetallic coil physically expands or contracts. This mechanical action is then translated into supplying more or less combustion air to the combustion chamber.

The catalyst in catalyst-equipped RWHs replaces the secondary combustion chamber of non-catalytic RWHs. Some catalyst have a metal substrate base but most are manufactured with ceramic substrates and active catalytic coatings which contain mostly precious metal oxides such as platinum and palladium. Catalysts are available in a variety of overall shapes and sizes, from 2- to 10-inch squares and rectangles to 6- to 8-inch circles. Most of them are from 2- to 3-inches in depth along the path of combustion gas flow and have a monolithic, honeycomb structure with 4 to 6 cells per inch.

Catalytic activity works to reduce the temperature at which chemical reactions such as wood-gas combustion take place. The same amount of chemical energy is released from the

combustion of wood generated gases when a catalyst mediates the chemical reactions but the temperatures at which the chemical reactions start taking place are reduced. Without catalytic mediation, the lowest temperature at which wood-gas combustion appears to be initiated is approximately 950°F. With the same gas mixtures, and when the gases are passed through a catalyst, this temperature is reduced to the range of 500 to 600°F. In addition, once catalyst mediated combustion is initiated the energy released generates temperatures in excess of the 950°F level so that wood-gases passing through the honeycomb spaces are combusted without coming in contact with the actual catalytically active surface. This phenomenon adds even more heat to the catalytic structure which is then capable of sustaining clean burning conditions under a wide range of catalyst inlet gas temperatures.

Figure 10 Contraflow heater with bakeoven

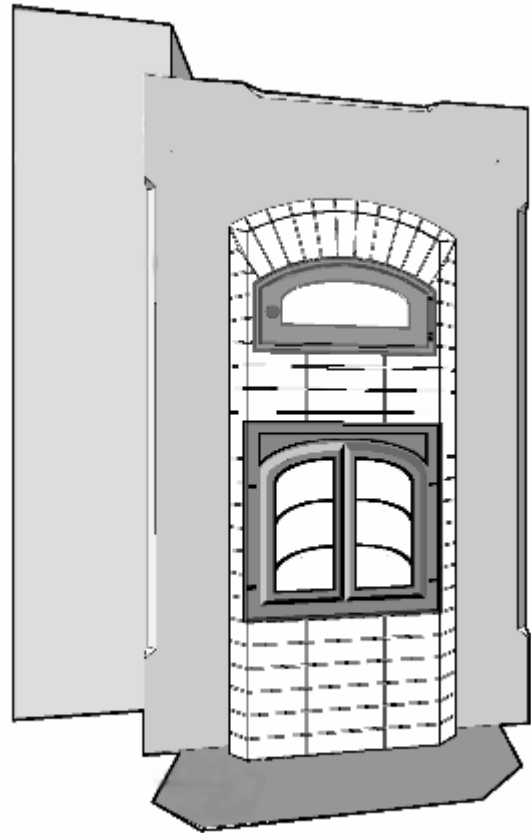

Most catalyst equipped RWHs also introduce heated secondary air to the gases leaving the primary combustion chamber. As in non-catalytic RWHs, this is done to ensure that adequate air-to-fuel ratios are maintained in the catalyst mediated combustion zone even if the primary air supplies are reduced by the action of a thermostat. Like non-catalytic RWH design features, catalyst equipped RWHs typically incorporate measures like insulating ceramic materials to conserve and hold heat in the secondary (catalyst) chamber. Because very high temperatures above 1000°F are maintained in catalysts for long periods of time during full fuel-load burn cycles, a wider range of air-to-fuel ratios and mixing turbulence can produce cleaner burning results than occur in non-

Each of the burn rate curves exhibits dramatic increases in emission factors as firebox size increases. As the burn rates increase, the slope of the emission-factor curves decrease and the larger the firebox is when the dramatic increases occur: i.e., larger fireboxes, and hence, fuel loads, require higher burn rates to maintain low emission factors.

It should be noted that since the standard test procedures call for a fuel loading density of 7 pounds of fuel per usable cubic-foot of firebox volume, each RWH is loaded according to its specific size. If several RWHs are each burned at seven pounds per hour, at the end of one hour, a 2 cubic-foot RWH burns half of its fuel load, a 3 cubic-foot RWH burns one third of its fuel load, while a 1 cubic-foot RWH consumes its

EFFICIENT COMBUSTION IS DIFFICULT TO ACCOMPLISH IN TRADITIONAL RWHs ESPECIALLY AT LOW BURN RATES DUE TO LOW COMBUSTION TEMPERATURES, POOR AIR-TO-FUEL MIXING, AND VARIABLE COMBUSTION CONDITIONS.

catalytic RWHs

Firebox/ Fuel load size

The capacity of a woodstove to hold fuel is determined by the size, or usable volume, of the primary combustion chamber or firebox. Many RWH manufacturers report that the U.S. market requires large volume RWHs which enable consumers to load large amounts of wood fuel. The ability to maintain long burn duration without reloading or adjusting the air supply settings is commonly regarded as a major marketing feature. As a result, most RWHs sold in the U.S. market have firebox volumes of about 1 to 3.5 cubic feet (28 to 100 liters). Data from EPA certification tests and from previous studies on fuel-load/firebox volume burn rate, and PM-10 emissions relationships⁽³⁾ were used to construct Figure 4.

All the data were from non-catalytic RWHs. The 1 kg/hour-burn-rate curve shows that emission factors are at approximately 5 g/kg in one cubic-foot firebox and increase rapidly as firebox sizes (and hence fuel load size) increase over two cubic feet. The small decreases in the 1 kg/hour emission-factor curve when firebox sizes increase to greater than three cubic-foot, are probably due to deposition losses of emissions on firebox and chimney walls.

entire charge.

The size of the fuel charge appears to be the primary critical factor. The batch process involved in fueling an RWH requires an entire fuel charge to be placed in the firebox at once. As the fuel load is heated, gasification of the wood occurs. The larger the fuel load, the greater the amount of wood subjected to gasification, resulting in greater quantities of wood gas being released over a given time. At a fixed heat output level, more wood gas will be released from a large fuel charge than from a small charge. Lower mixing intensities and more cool areas in larger RWHs will result in higher emissions (per mass unit of fuel burned), especially under low-fire conditions. Catalyst equipped RWHs are not as susceptible as the non-catalytic RWHs to the effects of firebox/fuel-load size.

As discussed previously, because of higher sustained temperatures, catalyst assisted secondary combustion accommodates a much greater range of air-to-fuel ratios and air/fuel mixing conditions. As long as the catalyst is sized correctly and an appropriate amount of air is provided, a catalyst equipped RWH will have lower emissions under just about any burning conditions.

Controlled Air Supply and Fuel Feed Rates

Efficient combustion is difficult to accomplish in traditional RWHs especially at low burn rates due to low combustion temperatures, poor air-to-fuel mixing, and variable combustion conditions. If air is mixed with fuel in a highly regulated and turbulent manner, higher temperatures and more efficient combustion can be achieved.

Mechanical draft systems, in which air is forced or drawn into the combustion chamber, are used on many wood fired furnaces and all types of small, mid- and large scale commercial and industrial boilers.

A forced draft system moves air into the combustion chamber under positive pressure;

Among RWH appliances currently available, virtually all mechanical draft stoves are designed to burn pelletized wood fuel. Pellets are typically $\frac{1}{4}$ inch to $\frac{3}{8}$ inch in diameter and about $\frac{1}{2}$ inch in length. The composition varies among manufacturers, but is primarily sawdust and chips from forest products operations. Some pellets are composed of wood only, while others contain more bark and debris. Most are formed under heat and high pressure, and most use no binder. Heat content of the pellets are typically in the same range as cordwood (i.e., 8750 to 9200 Btu/dry lb), with a moisture content of 6-10 percent. Pelletized fuel has been successfully used as a substitute for coal in many small boiler applications.

The primary advantage of using pellets in

THE COMBUSTION OF WOOD IN RESIDENTIAL WOODFIRED HEATERS (RWHS) INVOLVES HIGHLY COMPLEX CHEMICAL PROCESSES WHICH ARE SENSITIVE TO A WIDE VARIETY OF INFLUENCES. KEY ELEMENTS REQUIRED FOR EFFICIENT COMBUSTION INCLUDE HIGH COMBUSTION ZONE TEMPERATURES, APPROPRIATE AIR-TO-FUEL RATIOS, ADEQUATE AIR (I.E., OXYGEN) AND FUEL MIXING, AND ADEQUATE RESIDENCE TIME

i.e., higher pressures exist in the combustion chamber than in the surrounding space. Induced draft, on the other hand, draw exhaust gases out of the firebox, creating negative combustion chamber pressures. Both systems use fans to move the air and gases, hence the term mechanical draft. (Natural draft stoves are more properly "thermally drafted".) The use of a mechanical draft allows much greater control of combustion air flows and patterns, resulting in improved combustion conditions.

Both the induced and forced mechanical draft systems have advantages and disadvantages. Forced draft systems require higher quality construction methods to prevent combustion gases from leaking through doors and other openings into the surrounding space.

Induced draft systems do not require a perfectly sealed system, as most leaks will simply draw air into the combustion chamber or flue. Induced draft fans, however, must move hot and sometime dirty gases, requiring more care in selection and maintenance of fans and motors. In addition, mechanical draft RWHs will not operate without electric power to drive the fans, so these units can not be utilized during power outages.

residential combustors is the ability to control the amount of fuel involved in combustion at any one time. Air and fuel feed rates are then both controlled, providing optimized combustion conditions. Pellets can be fed at a constant rate into a combustion zone maintained at high temperatures and high turbulence by a forced or induced draft.

The mass of fuel involved in combustion at any time is very small, while oxygen supplies and turbulence are high. Pellet stoves can operate under steady state conditions as a continuous process, rather than the batch process of burning cordwood. The small mass of fuel burning at any given time promotes stable, near steady state conditions, which allows more efficient combustion. Pellet-fired RWHs with appropriate air-to-fuel ratios (i.e., in the rage of 15:1 to 19:1) have efficiencies and emissions comparable or better than catalytic RWHs.

On all existing pellet-fired RWH designs, fuel is stored in a hopper and moved into the combustion chamber/firebox with a motorized auger or cupped-wheel design. The feed rate is controlled by variable speed motors or automatic/electronic time-on switches. Pellets are pushed or dropped into a small cup-shaped

tray which is surrounded by combustion air inlet jets, creating a concentrated and intense burn region. Air supply fan speeds can also be varied; some pellet-fired RWHS have combined single-control air and fuel feed rates while others offer combinations of independent fan and fuel feed rates controls, and continuous or intermittent operation. Most pellet-fired RWHS use a refractory lined combustion chamber in which the pellet "burnpot" and air supply ring are located. Gases are then vented from the combustion chamber through heat exchange baffles.

CONCLUSIONS

The combustion of wood in Residential Woodfired Heaters (RWHS) involves highly complex chemical processes which are sensitive to a wide variety of influences. Key elements required for efficient combustion include high combustion zone temperatures, appropriate air-to-fuel ratios, adequate air (i.e., oxygen) and fuel mixing, and adequate residence time. The batch process of wood combustion in the naturally drafted RWH presents special problems in that the entire fuel charge is involved in various and changing states of a complete combustion processes throughout the fuel-load burning cycle. Ideal conditions vary during each stage, making complete and efficient combustion of the entire fuel charge in a single RWH configuration very difficult. At best, present designers of naturally drafted RWHS provide optimized averages for the burn cycle: complete and efficient combustion for all stages of the burn cycle have not been perfected.

A variety of RWH technologies have been examined for their effectiveness in emissions reduction and for their appropriate measurement and reporting units. Conclusions drawn include:

1. The most useful and technically sound reporting unit for all RWH appliances and masonry heaters would be grams of emissions discharged per unit of useful heat produced. These units have not been used because no verifiable measurement methods were available at the time applicable regulations were being written.
2. The g/kg and g/hr reporting units must be used with caution when applied to the performance of EPA-regulated or EPA-exempted RWH appliances:
 - a) G/hr can be used to indicate the performance of EPA-regulated RWH appliances (EPA calls them affected facilities) only because of the limitations imposed by EPA's definition of affected facilities and the specificity of the test methodology utilized to measure their emissions performance. It is only because these limitations and specificity impose such a narrow range of sizes, design configurations, and test-condition operating protocols that the g/hr reporting units can be used for ranking one RWH against another. G/hr should not, however, be used to estimate the field performance of RWH appliances or typical real emissions.
 - b) The g/hr reporting unit is not appropriate for masonry heaters because burn times are short resulting in high g/hr values when g/kg values are low. G/kg is the most useful reporting unit for masonry heaters because it does directly reflect the quality of the burning process taking place. In addition, with g/kg data and defined construction specifications, masonry heaters can be fairly ranked against one another.
 - c) Since g/kg is the most useful unit for indicating the quality of the combustion process taking place, it would also be useful for comparing the currently regulated RWH appliances (i.e., woodstoves and pellet-fired stoves) with masonry heaters and any other wood burning appliances.
3. Smaller fuel charges required with smaller fireboxes reduce emission rates when compared to larger fuel loads consumed at comparable burn rates.
4. Air entering the firebox near or up through the coal bed ("underfire air") results in higher emissions.
5. Preheated secondary air, or more properly termed, additional wood-gas combustion air, introduced as combustion gases leave primary combustion zones and enter secondary combustion chambers can effectively reduce emissions.
6. Thermostatic air supply controls on non-catalytic RWHS cause air-starved conditions and high emissions when fuel load and firebox temperatures are high and the thermostat closes the damper.
7. Pellet-fueled RWHS utilizing mechanically assisted drafts have demonstrated emission

rates below the most efficient cordwood burning RWHs. This is due to externally powered controls for fuel feed and air supply which maintain ideal air-to-fuel ratios and mixing conditions.

Wood combustion involves a large number of highly variable parameters which can cause a high degree of variability in pollutant emissions. Certification testing, conducted by any current or proposed method, necessarily allows a range of test conditions. For example, there are allowed ranges of wood moisture, fuel loading density, and starting and ending temperatures. Although in most cases these ranges are narrow, they do produce error ranges or "noise" in resulting data. This "built-in noise," combined with the variable conditions of wood combustion, makes statistically significant isolation and quantification of RWH design factors difficult. However, as presented here, generally consistent differences can be seen between many design variables using the currently available data base.

REFERENCES

1. Residential Solid Fuels, Environmental Impacts and Solutions, J.A. Cooper and D. Malek, Oregon Graduate Center, Beaverton, Oregon, 1982, 1271 pages.
2. P. Burnet, J. Houck, P. Tiegs, et al., "Particulate, Carbon Monoxide, and Acid Emission Factors for Woodburning Stoves," Journal of Air Pollution Control Association, 36(9): 1012-1018 (1986).
3. Federal Register, Wednesday, February 18, 1987; Proposed Rules, Volume 52, Number 32 (DCN No. 86-231-020-25-04), page 4994-5066.
4. P. Burnet and P. Tiegs, "Woodstove Emissions as a Function of Firebox Size," Paper 84-87, 21st Annual Meeting, PNWIS/APCA, November 12-14, 1984.

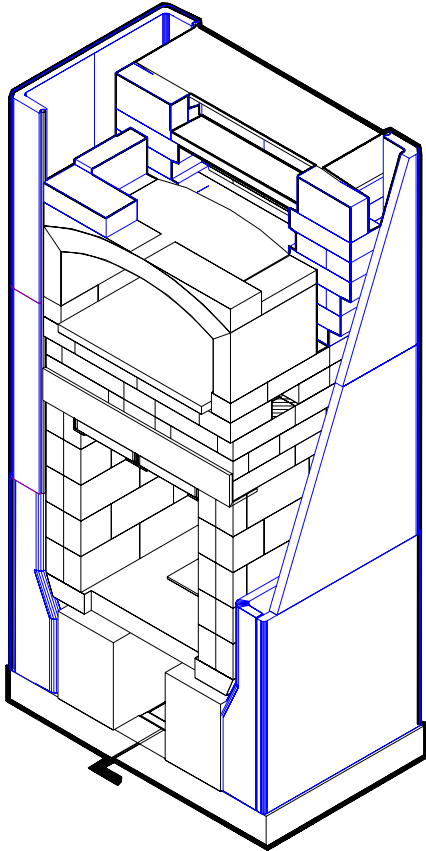

The Hearth as an Element of the Sustainable House - A Comparison of Emission Test Methods for New Clean Burning Wood Fired Masonry Fireplaces

Norbert Senf
Masonry Stove Builders
RR 5
Shawville, Québec J0X 2Y0

Draft of a paper to be presented at 89th annual meeting of the Air and Waste Management Association, June 23-28, 1996, Nashville TN

Introduction

This paper details a research project funded primarily by Western States Clay Products Association (WSCPA) and carried out in the Spring of 1995 that compared 3 different methods for measuring fireplace emissions. In addition to presenting the test data, sustainable housing issues will be introduced in order to place the results and conclusions in a larger context.

History of the Hearth

The first controlled use of fire by man predates our own species, and is now believed to have occurred 1.4 million years ago by *Homo erectus*. Agriculture, in contrast, is only about 10,000 years old. Although chimneys were known in Han China 2,000 years ago, they only came into general use among our British forebears around the sixteenth century.

The open fireplace was brought to this continent by our British ancestors. In our colder North American climate, it was replaced for primary heating by the closed combustion iron stove in the eighteenth century. Even to this day, it is still commonly used as a main heat source in the British Isles. This ancient relationship with fire continues to this day even though few people still carry the awareness that the words "hearth" and "heart" share a common origin.

Other European cultures had parallel developments, but with different technological outcomes. Of particular interest recently has been the masonry heater, which differs from the fireplace in having the ability to store large amounts of heat in a thermal mass. Recent North American research into masonry heater performance has been reported previously. Although there is now an overlap between masonry fireplaces and masonry heaters, data for this report was obtained from tests done on two variations of the traditional masonry fireplace, the Rumford and the Rosin.

Defining Sustainability

In keeping with the theme of this year's AWMA conference, it is useful to examine fireplace performance issues from the viewpoint of sustainability. Woodburning has the potential to be a sustainable technology, but it must be done with high efficiency and low emissions. While sustainability may seem at first glance to have an obvious definition, further examination reveals that it is in fact a complex and multi-layered subject. The First International Conference on Sustainable Construction took place in 1994, and defining sustainability occupied two of the fifteen sessions. Conference coordinator Charles Kibert noted that the concept of sustainability is not a new one. It became part of the environmental vernacular in 1987 when the Brundtland Report described sustainability as "leaving sufficient resources for future generations to have a quality of life similar to ours."

Dr. Kibert makes a comparison of the traditional building construction criteria of performance, quality and cost with sustainability criteria of resource depletion, environmental degradation, and a healthy environment. This is summarized in Table 1.

This suggests a context for the fireplace emissions research described in this paper. Namely, we may start with a generalized set of sustainability criteria and then ask how the research addresses these criteria. This has the benefit both of placing it in a larger context and also suggesting an approach for future research.

A comparison of the traditional masonry fireplace with the prefabricated metal fireplace is made using traditional criteria in Table 2 and sustainability criteria in Table 3.

This is admittedly a tentative analysis and reflects the fact that explicit regard for sustainability criteria is a new and evolving trend in the field of building construction

Moving Towards Sustainability

Research into fireplace emissions is surprisingly recent.

Table 4 compares US-EPA field test data for masonry fireplaces with other RWC (residential wood combustion) appliance types. Emissions, on average, appear to be high compared to current woodstoves. Early research indicates that there may be several avenues towards reduced emissions, yet most of them are virtually unexplored.

In the transition to a more sustainable economy, the masonry fireplace must move from its current position as a symbol of wealth and leisure to reclaiming its role as an active and central part of the household. Although this report deals with conventional masonry fireplaces, it should be noted that advanced masonry fireplace technology already exists in the form of masonry heaters and has been reported on previously.

The ability to use minimally processed, locally grown fuel for domestic heating is a realistic option in many locales on this continent. The obvious environmental benefit is that firewood can be a renewable fuel. It can help us to live off annual solar income and reduce our dependence on fossil fuels.

There is a caveat attached to firewood use, however. Grown, harvested or burned improperly, it can also become an environmental liability. More emissions research is badly needed.

Particulate Matter (PM) Emissions

PM emissions are the main focus of North American regulatory activity. Part of the reason that they are avoided by European regulators may be due to the fact that they are not easy to define or to measure. This is due to their chemical complexity and variability. They include semi-volatile hydrocarbons that only condense into smoke particles upon atmospheric mixing and cooling. Wood smoke particulates tend to be smaller than 10 microns (PM10) in size, and have been identified as a potentially serious health hazard where their ambient

concentrations are high for prolonged periods. In built up areas woodsmoke can also be a severe nuisance and in some jurisdictions there is legislation to penalize the owners of offending appliances that let wood smolder. This smoldering characteristic can result in a 100:1 ratio of emissions between appliances and operating techniques at either end of the scale.

Regulation

PM emissions from woodstoves are regulated in the United States by the Environmental Protection Agency (US-EPA). A peculiarity of the legislation is that it does not apply to high mass masonry appliances and in fact neither of the two specified laboratory test methods are practical with high mass appliances.

A second peculiarity is EPA's definition of PM. To quote the regulation: "Test methods are an integral part of any regulation and the emission limit is related directly to the method. This is especially true for PM because PM is not an absolute quantity, but rather is defined by the test method." This links directly to the current research. Although high mass appliances are explicitly excluded from regulation, local jurisdictions have nevertheless demanded that masonry heaters and, more recently, masonry fireplaces provide "equivalent to EPA certified" data. An additional complication is introduced by the fact that, after evaluating initial efforts to develop a laboratory testing protocol for masonry appliances, EPA ruled that only field data from actual in-home use could be used to determine "equivalent to" numbers for regulatory purposes.

Test Methods

As indicated in the above discussion, the subject of test methodology has become a central issue with respect to establishing masonry appliance PM emission numbers. Manufacturers would like to use a test method that is simple and low cost. Regulators main criteria are accuracy and inter-laboratory repeatability. As alluded to above, the subject of PM test methods is anything but simple. Not only is the definition of PM a variable that is embedded in the particular test method, but there is the additional requirement to generate field test data that can be compared with laboratory-specific methods. A brief summary of common PM test methods follows.

US-EPA Methods

Two types of test methods define the EPA standard, a laboratory fueling protocol and a PM sampling method.

The laboratory fueling protocol is known as Method 28 (US-EPA-M28). It specifies standardized fuel cribs that are assembled from douglas fir dimensional lumber. It also specifies a method for establishing a series of standardized burn rates by placing the stove on a scale and adjusting the combustion air supply setting. Emissions during the cold start phase are not addressed, and a hot-to-hot burn cycle, starting and finishing with a charcoal bed, is used.

PM is defined by two different methods in the 1988 EPA rule, Method 5G (US-EPA-M5G) and Method 5H (US-EPA-M5H). Empirical data at the time indicated that the methods produced differing PM numbers, and the rule defines a conversion factor between the two.

The following description of the two PM measuring methods is taken from the regulation:

M5G. Particulate matter is withdrawn proportionately at a single point from a total collection hood and sampling tunnel that combines the wood heater exhaust with ambient dilution air. The particulate matter is collected on two glass fiber filters in series. The filters are maintained at a temperature of no greater than 32°C (90°F). The particulate mass is determined gravimetrically after the removal of uncombined water.

M5H. Particulate matter is withdrawn proportionally from the wood heater exhaust and is collected on two glass fiber filters separated by the impingers immersed in an ice bath. The first filter is maintained at a temperature of no greater than 120 °C (248 °F). The second filter and the impinger system are cooled such that the exiting temperatures of the gas is no greater than 20 °C (68°F). The particulate mass collected in the probe, on the filters, and in the impingers is determined gravimetrically after removal of uncombined water.

Method 5G uses a dilution tunnel which mixes the stove exhaust with atmospheric air before sampling. This most closely resembles the real world, where some of the hydrocarbons only condense into smoke particles after being cooled in the atmosphere. The cooled and diluted sample is passed through a set of filters that

collect the particulate. In Method 5H, a hot sample is drawn directly from the stack. The particulate is collected in fractions by passing the sample in series first through a hot filter, then through several cold impingers and finally through a cold filter.

Other Methods

A more detailed description of three other test methods, used in this study, is given below. The first method is essentially EPA Method 5 modified for field use that employs aspects of both M5G and M5H. The second method (AES) is an EPA-recognized field testing method with a long track record. The third method (OM41), although it was used by most stove manufacturers to develop current EPA Phase II technology, is not recognized by EPA. It is low cost and simple, and has been used extensively at Lopez Labs to develop a masonry fireplace and masonry heater performance database.

Methods used in this study

A fueling protocol developed by the author and colleague J. Frisch at Lopez Labs was used in most of this study. The Lopez protocol differs from EPA-M28 in that it uses real world fuel. Limited earlier testing on two masonry heaters indicated that use of dimensioned lumber could reduce PM emissions by approximately 50%.

The Lopez Labs fueling protocol uses cordwood. Instead of sizing, it is a specification for describing the fuel load in enough detail to allow the original initial condition in the firebox to be reconstructed at a later date.

Three separate PM measurement methods were run simultaneously in this study.

Modified EPA-M5G. This method was conducted by S. McNear from McNear Brick, the site of the testing, and Dr. D. Jaasma from Virginia Polytechnic. It consisted of a Method 5G dilution tunnel and a modified method 5H filter train. Two filter trains were run in parallel to provide data redundancy. Flow rate through the tunnel was measured with a pitot tube and held constant by means of a variable speed fan. A sample was drawn from the tunnel with a constant flow rate gas pump, thus providing a sample with a fixed proportion to the total tunnel flow.

Automated Emissions Sampler (AES). This method was conducted by P. Tiegs and J. Tiegs

from OMNI Environmental (Beaverton, Oregon). The AES unit is a portable emissions sampling system. Flue gas is drawn from the stack and the sample travels through a heated filter for collection of particulate matter. The filter is followed by a cartridge containing a sorbent resin for collecting semi-volatile hydrocarbons. Flue gas oxygen concentration is measured by an electrochemical cell.

A calibrated orifice is used to maintain a constant sample flow. A subsample of this flow is pumped into a Tedlar bag for laboratory analysis of average carbon dioxide and carbon monoxide concentration and to confirm average oxygen concentration as measured in the field.

The AES system operates automatically for the duration of the test period (typically one week) except for daily input of fuel weight data into a computerized data acquisition system. For this study, the AES was run in a daily mode in order to yield discrete data on individual burns.

Oregon Method 41 (OM41). An appliance developer has a different set of criteria in choosing a testing method than a regulator does. The regulator has a rigorous and legalistic set of criteria, and is shielded from financial burden. The developer is paying from his own pocket, and cost/benefit ratio is at the top of his list of requirements. As a result, early woodstove research and development programs did not use Method 5 dilution tunnels. They used the Condar dilution tunnel, which was developed by the late Dr. Stockton Barnett, one of the pioneers of modern woodstove performance testing. This method became an official method in Oregon, the state that originated woodstove regulation, and is known as Oregon Method 41 (OM41).

An interesting discussion of the relative merits of OM41 from an EPA perspective is found in the preamble text of the actual regulation: (the author's comments appear in italics)

One commenter argued that the Oregon Method 41 (OM41) should be allowed as a compliance test method for the wood heater regulation because of being less expensive and easier to use. Eight commentators petitioned the Agency to approve the use of OM41 for QA testing, noting that the method is recognized in Oregon as equivalent to Oregon Method 7. Comments made in support of OM41 included: (1) A

significant amount of data from simultaneous tests with OM41 and Oregon Method 7 verifies the high correlation between the results of the two methods; - (2) the initial cost of implementing OM41 is half that of either Method 5H or 5G; (3) OM41 uses short-interval sampling and provides instantaneous results, two factors valuable in diagnosing and evaluation of wood heater design; (4) OM41 is easy to prepare, calibrate, and operate with limited technical training; (5) OM41 samplers have been calibrated by the manufacturer to produce a standardized instrument for the industry, as opposed to the EPA methods which must be calibrated frequently on site; and (6) OM41 equipment is compact and portable.

EPA has considered this test method, but is not approving it for certification or QA testing....Deficiencies include: (1) The data reported in the literature comparing the OM41 results with other test method results do not include many values in the range expected for compliance testing of NSPS wood heaters (<10 g/hr). (2) The OM41 sampling rate is not proportional to the flow rate in the wood heater stack, which is necessary for accurate measurement; (3) sample volume is not measured directly, but is calculated from orifice readings (*author's comment: this is not entirely accurate—the orifice and manometer are factory calibrated as a system*) (4) the stack gas flow rate is not determined using a carbon mass balance approach as is used in the Oregon DEQ and the Method 5H procedures; and (5) the dilution temperature in the OM41 sampler is dependent on the temperature of the wood heater and, thus, is a variable (*author's comment: a thermocouple tracks tunnel temperature which is always lower than 90 °F, as in M5G*)

Another reason is that there was no suggestion or support during the negotiations for the inclusion of OM41 as a third test method for either certification or QA testing purposes.

Test methods are an integral part of any regulation and the emission limit is related directly to the method. This is especially true for PM because PM is not an absolute quantity, but rather is defined by the test method. Application of more than one test method to a regulation needlessly complicates enforcement and may even result in unequal enforcement of the standards. Because of these considerations, the regulatory negotiation process for the wood heater regulation resulted in two certification test methods with a correlation factor for comparability of the two method's results.

Wood heater manufacturers may continue to use OM41 for a number of internal purposes. These include collection of interval emission samples and sampling during field evaluation. For the reasons cited above, the OM41 method is not acceptable for use in QA tests that manufacturers are required to perform.

(p 5870) One commenter raised the issue of how EPA would deal with a manufacturer who wanted to have an exempt appliance certified. An appliance that is not an affected facility is not regulated. With limited resources, EPA does not intend to certify appliances which are outside the scope of the regulation's coverage.

Comparing Test Methods

Exemption from EPA regulation for masonry high mass appliances soon turned from an asset to a liability when federal air quality regulation was implemented on a local state and county level. "EPA certified" became the lingua franca and the distinction between "uncertified" and "non-affected" as defined in the federal regulation was not considered legally definitive enough for local regulators and their counsel to feel comfortable.

For an industry response, one obvious deficiency was the lack of correlation data for different PM test methods as they applied to high mass appliances. EPA has decided that only field test data is acceptable for comparing different appliance technologies. Accordingly, work at Lopez Labs was done in simulated field test

style. Real world fuel was used and appliances were fired on real world time cycles. As well, both operators are experienced wood heat users and also share a large historical client base of masonry fireplace and masonry heater users.

The McNear Brick Tests

In 1995, Western States Clay Products Association (WSCP) sponsored a series of field tests of 2 masonry fireplaces. Three methods were used simultaneously — a modified EPA-M5G, an AES and OM41 as modified for use at Lopez Labs. An unheated concrete shed at the McNear brickyard in San Rafael was the test site. Weather conditions were severe and included high winds and nearby flooding.

Fireplaces Tested

Frisch Rosin. The Frisch Rosin fireplace is based on the Rosin firebox, developed in 1939 by Professor P.O. Rosin at the Institute of Fuel in Great Britain. Using the principles of dimensional analysis, Rosin applied findings from fluid model studies to full scale masonry fireplaces. It became the largest selling prefabricated fireplace system in the world until the advent of the cheap metal "builder's box" in the 1970's. It consists of a curved precast refractory firebox and a refractory hood. It has no smoke shelf. In the Frisch-Rosin design, an airtight ceramic glass door is added to the basic Rosin. The main feature is the combustion air supply, which is fixed. It is very simple, consisting of a 1" i.d. air tube on either side that is aimed directly at the fire.

Buckley Rumford. The Buckley Rumford uses the traditional Rumford fireplace design. Initially designed as a retrofit for the huge fireboxes of the day, it gained wide popularity. It reduced the depth of the firebox considerably and added splayed sides. This increased the radiation of heat into the room considerably. It also added a throat and a smoke shelf.

An important feature is the curved chimney breast. This is the trailing edge of the top of the fireplace opening. Rosin's aerodynamic models clearly show eddies at this point for a standard fireplace with a square edge. A 30" Buckley Rumford with 18" of 8x12 flue was used for the McNear tests.

Test Description

Buckley Rumford. Prior to the tests at McNear Brick, 6 tests in the open fireplace mode were performed on the Rumford fireplace at Lopez Labs using OM41. A total of 7 test runs were done at McNear Brick. All runs were in the open fireplace mode. All three test methods were used for three tests, dilution tunnel only was used for three tests, and for one test there is tunnel and OMNI data. Fueling for the tests was variable, and on some tests included the use of a gas log lighter. Ten additional tests were later performed at Lopez Labs using OM41 on the same model equipped with airtight glass doors.

Frisch Rosin. Prior to the tests at McNear Brick, 26 tests spread over two years were performed on the Rosin fireplace at Lopez Labs using OM41. Four of these tests were with the same combustion air configuration (Frisch) that was used for the California tests and have been reported previously. A total of 10 tests were performed at McNear Brick. There is OM41 data for all 10 tests, M5 data for 5 tests, and data from all three methods for 2 tests. In addition, a second AES system was run in normal (non-discrete) mode for a 7 day certification run. Subsequent to the McNear tests an additional 9 tests were conducted at Lopez Labs on a standard site-built fireplace using the Frisch air supply. All tests with the Frisch air supply were run with the airtight glass doors closed and with identical fuel configurations, with the fuel load kindled from the top (“top down” burn).

Test Results

Data used for this report

A total of 18 tests were run at McNear Brick, including conditioning runs on the appliances. Data for this report is taken from summaries provided by the participants as well as copies of the original laboratory notes for the M5 and OM41 data. Nine test runs used two or more test methods simultaneously. Data from the last 6 of these 9 tests is used for this report due to various problems during initial tests. In addition, data from the 7 day AES certification test on the Frisch Rosin is reported.

Test Results

Test results for the 6 comparison tests are summarized in Figure 11. Tests 1 – 4 are on the open Buckley Rumford and tests 5 – 6 are on the closed Frisch Rosin. The difference between open and closed combustion is readily apparent

on the chart from the larger error bars on the AES open fireplace data due to higher dilution. For the closed tests, clustering of the data points is noticeably tighter.

Test results for the AES certification run on the Frisch Rosin are summarized in Table 5.

TESTING ISSUES

Fueling protocol

Experience gained from the original masonry fireplace tests at Virginia Polytechnic with dimensioned lumber led to the conclusion that Douglas Fir cordwood should be the fuel of choice for field testing to avoid having to correlate the two fuels. Experience with cordwood at Lopez Labs over four years of fireplace and masonry heater testing has resulted in the development of a Lopez Labs fueling protocol. Rather than being a fixed fueling method, it is a specification for documenting the fuel charge in enough detail to allow the initial firebox condition to be reconstructed at a later date.

Emission Rate vs. Emission Factor

The EPA regulation specifies woodsmoke quantity as a mass (grams). The emission unit defined is a rate (g/hr), rather than a factor (g/kg). This has turned out to be somewhat unfortunate for masonry appliances. A simple example drawn from the masonry heating field will illustrate this point: Masonry heaters exploit the thermal mass property of masonry to store heat by burning a charge of fuel rapidly, storing the heat, and then radiating into the room over an extended time. For example, 20 kg of wood might be burned in one hour and provide heat for 12 hours. If the emission factor were typical at around 2 g/kg, the emission rate would be 40 g/hr for one hour and 0 g/hr for 11 hours. Is this a 40 g/hr stove, a 0 g/hr stove, or a 3.3 g/hr stove?

Sensitivity to high combustion air dilution ratios

Two of the test methods, the AES and the OM41, rely on a measurement of stack oxygen to determine an emission factor or rate. As the stack oxygen approaches ambient (20.9%), the dilution ratio increases exponentially. In other words, to maintain accuracy at high dilution rates the resolution of the oxygen measurement equipment must increase as oxygen approaches

ambient. This results in a loss of accuracy for open fireplaces with high air dilution ratios. This is reflected in the error bars for the AES in Figure 11. Tests 5 and 6, which are with doors closed (and hence less dilution) have much smaller error bars than tests 1 to 4. Since EPA-M5 does not rely on oxygen values, it has a theoretical advantage over the other two methods at high dilution ratios, i.e., for open fireplace testing.

Sensitivity to particulate sampling parameters

Both the M5 and OM41 methods at McNear Brick involved weighing of filters and residues on site. The OM41 uses 6" filters and M5(McNear) uses 2" filters. With 9 times the filter area, the OM41 filter train can therefore handle a larger fraction of the flue flow. Filter catch is determined by the dilution ratio in the tunnel and the sampling rate. Using the data from test 0 as an example: filter catch for OM41 was .0733 grams and for M5 was .00095 grams. The PM factor to filter catch ratio (PM factor/catch) for OM41 is 30.15 and for M5 is 9252, or 300 times greater. M5 is therefore considerably more sensitive to resolution and accuracy limitations of the analytical balance as well as the weighing procedure.

Filter weighing at Lopez Labs is done on an analytical balance that is regularly calibrated by a certified technician. Resolution at the .0001 gram level is achieved with a vernier scale and requires some operator skill. The balance is installed on special mounts and kept in a climate controlled low humidity room. Filters are conditioned in this room for 30 minutes after being taken out of a desiccation cabinet. With 6" glass filters and .0001 gram balance resolution, moisture-induced weight changes can be observed in real time. An adjustment routine has been included in the testing spreadsheet to automatically compensate for small room humidity variations. Before climate control was installed, a sensitivity analysis of approximately 150 tests at Lopez Labs over 3 years revealed an average PM factor error of 0.1 g/kg due to moisture effects on the filters. If a 50 times lower flue gas sampling ratio were used, this would translate into an unacceptable 5 g/kg effect due to filter moisture variations. The McNear field tests took place in an unheated, humid concrete building during a time of very variable outside weather that included high

winds and flooding. Therefore, a sensitivity analysis of the chosen filter and dilution parameters seems a reasonable precaution before future testing is carried out. It should also be noted that a dual filter train would be transparent to calibration error in the balance, since error would be expected to affect both sets of filters equally.

For the McNear tests, separate balances were used by the three participants. For the two methods where filters were weighed on site (M5 and OM41), use of two different balances introduced an additional and unnecessary degree of freedom.

Other Lessons Learned

Subsequent use at Lopez Labs of the OM41 system used at McNear Brick revealed a leak due to a cracked filter housing. Since a significant data base exists at Lopez on the Frisch Rosin fireplace that was tested at McNear Brick, it was possible to deduce that the leak probably existed at McNear Brick. Subsequent recalibration of the OM41 system at Lopez allowed a correction factor to be calculated for the closed door tests at McNear Brick. The data presented in Figure 11 is uncorrected, since the correction factor is not meaningful for the 4 open fireplace tests, due to the high dilution ratios. An automated leak detection routine has been implemented for the Lopez gas analyzer, so that this problem should not reoccur.

Conclusions

As indicated, a number of data resolution and accuracy issues were seen with all three test methods. Considering that this was the first ever attempt to run these three methods simultaneously under field conditions, this is not unexpected. This is particularly so in view of the fact that there were also some extreme environmental conditions. Indeed, a most valuable aspect of this testing is that they provide a more solid foundation for future work. It should also be noted that, in addition to J. Frisch from Lopez Labs, two recognized authorities in RWC laboratory and field testing, Dr. D. Jaasma and P. Tiegs, were also present for the one week duration of testing. This afforded members of the masonry fireplace industry a unique opportunity to access this expertise in the cause of improved testing methods for masonry appliances.

The AES certification test results for the Frisch Rosin with the Frisch air supply are noteworthy. While it is only a single data point due to the cumulative nature of the AES method, it is in good agreement with both the discrete McNear Brick data as well as prior Lopez Labs data and subsequent Lopez Labs data. It appears likely that site-built clean burning masonry fireplaces are possible.

Additional research and appropriate building code changes, or similar regulation, seem more appropriate than legislating the masonry fireplace out of existence based on the very limited emissions testing database to date. A more detailed sustainability analysis of clean woodburning should certainly become a priority. The air quality policy debate should be broadened to include sustainability issues such as greenhouse gas emissions.

Discussion

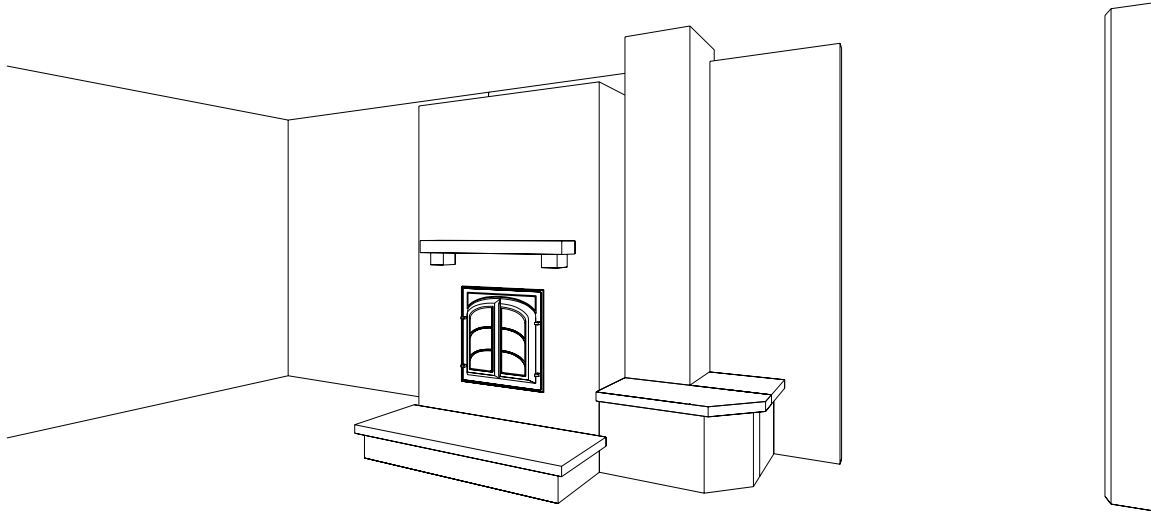

Table 1. Comparison of traditional criteria with sustainability criteria

Traditional Criteria	Sustainability Criteria
Performance	Resource depletion
Quality	Environmental degradation
Cost	Healthy Environment

Table 2. Fireplace comparison using traditional criteria*******(Note: preliminary)**

Traditional Criteria	Conventional Masonry Fireplace	Prefab Fireplace
Performance	Low efficiency	Higher efficiency
	High emissions	Low emissions
	Open fire, renewable fuel	Simulated wood fire using fossil fuel
Quality	Traditional craftsmanship, in decline	Mass produced, simulated craftsmanship
Cost	Higher	Lower

Table 3. Fireplace comparison using sustainability criteria*******(Note: preliminary)**

Sustainability Criteria	Conventional Masonry Fireplace	Prefab Fireplace
Resource depletion	Natural materials (clay)	Highly processed materials (steel)
	Embodied energy: low (adobe) high (hard clay bricks)	Embodied energy: high
	Long lifecycle	Short lifecycle (20 years)
	Reusable materials (using appropriate mortars)	Burns fossil fuel
Environmental degradation	High emissions	Low emissions
	Low greenhouse emissions	High greenhouse emissions
Healthy environment	“Heart” of the home, psychological well-being	Simulated well-being

Table 4. Comparison of US-EPA (AP41) field tested emissions by RWC appliance type

RWC Appliance Type	PM emission factor, g/kg
Masonry fireplaces	17.3
Masonry heaters	2.8
Woodstoves (non-catalytic)	
Pre-EPA	15.3
EPA Phase II certified	7.3
Pellet Stoves	
Uncertified	4.4
EPA Phase II certified	2.1

Table 5. Test results for the 7 day AES certification field test of the Frisch Rosin fireplace

Parameter	Value
PM Emission Factor, g/kg	2.2
PM Emission Rate, g/hr	2.9
CO Emission Factor, g/kg	44
CO Emission Rate, g/hr	59.7
Net Delivered Efficiency, %	57.9
Average Heat Output, BTU/hr	15,184
Average Burn Rate, dry kg/hr	1.33

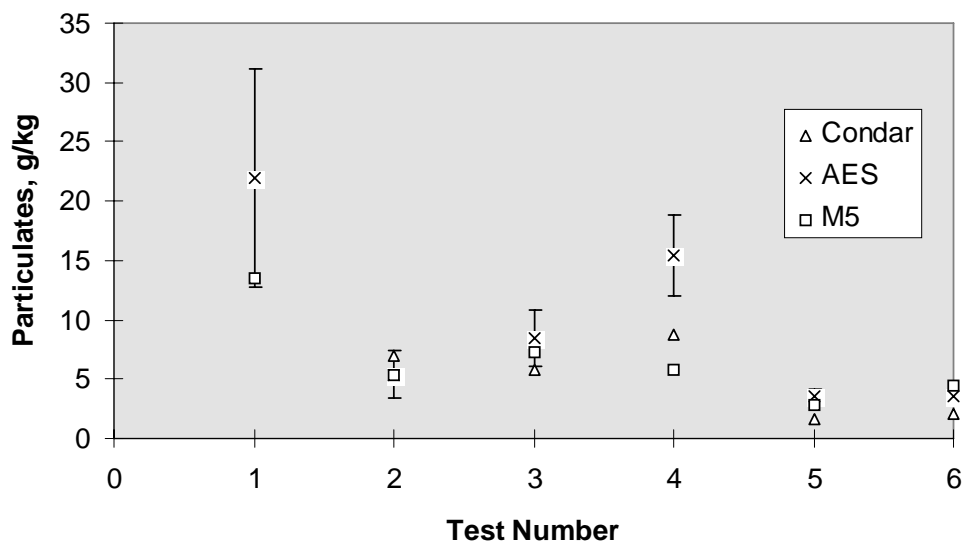
**Figure 11. Comparison of masonry fireplace PM emission factors as measured by three different test methods**

Short Course on Masonry Heating Systems

by:

Norbert Senf

Masonry Stove Builders / Lopez Labs

RR 5, Shawville, Que. J0X 2Y0

V 819.647.5092 F 819.647.6082

e-mail: mheat@travel-net.com

Presented at

All Fuels Expo 96

Burlington, Vermont

February 2, 1996

Short Course on Masonry Heating Systems

Introduction:

What is a masonry heater?

A masonry heater allows wood to be burned for home heating in a unique way. It's main distinction is the ability to store a large amount of heat. This means that you can rapidly burn a large charge of wood without overheating the house. The heat is stored in the masonry thermal mass, and then slowly radiates into your house for the next 18 to 24 hours.

This results in a number of benefits. If you burn wood fairly rapidly, it is a clean fuel. It has a low ash content and almost no sulfur content. If you try to burn it too slowly, however, the fire will change from flaming to smoldering combustion. The burning process is incomplete and produces tars. Atmospheric pollution increases dramatically. The ratio of emissions between complete and incomplete combustion with wood can be as high as 100 to 1.

These characteristics of wood combustion become very important if we are planning a wood fired heating system for an energy-efficient house. The average energy demand of this newer type of house is often quite low. For most of the time, it may require only 1 to 2 KW of heat. For most conventional woodstoves, this is below their "critical burn rate", or the point where they start to smolder. In other words, woodburning and energy efficient houses don't really suit each other very well, unless you have some way to store heat so that your stove can operate in the "clean" range all of the time.

Masonry heaters fill the bill very well. If you need even a very small amount of heat, such as between seasons when you simply want to take off the chill, you simply burn a smaller fuel charge—yet you still burn it quickly. The large surface is never too hot to touch. You have a premium radiant heating system with a comfort level that is second to none.

Brief history

The first controlled use of fire by man predates our own species, and is now believed to have occurred 1.4 million years ago by *Homo erectus*. Agriculture, in contrast, is only about 10,000 years old. Although chimneys were known in Han China 2,000 years ago, they only came into general use among our British forebears around the sixteenth century. Interestingly, of the northern European cultures only the British and French have an open fireplace tradition. Since our North American heritage is mainly British and French, we share this tradition. Not surprisingly people in both countries, peasant and nobleman alike, used to basically freeze in the winter. In our harsh North American climate, the open fireplace was replaced for primary heating by the closed combustion iron stove in the 18th century. The open fireplace is commonly found to this day as a main heat source in the milder climate of the British Isles.

We still carry this ancient relationship with fire in our consciousness, even though few people are still aware that the words "hearth" and "heart" share a common origin.

Other northern and middle European cultures had a somewhat different development that led to a masonry heating tradition. Several different heater types evolved in separate regions. Four types are commonly recognized in North America, and will be described later.

Wood Combustion Fundamentals

Combustion chemistry

From high school chemistry, we recall that all chemical compounds are formed by a combination of about a hundred chemical *elements*. The elements can neither be converted into each other nor split into simpler substances by chemical means. The elements are represented by symbols. The symbols of interest to us for the combustion chemistry of wood are carbon (C), hydrogen (H), and oxygen (O).

Wood combustion is a complicated process consisting of several main chemical reactions and a very large number of intermediate reactions. Depending on the conditions in the firebox, many alternate paths are available to the reacting compounds. As you know, when wood is burned the range of possible products that can leave the stack is very wide.

Elementary analysis

Wood has a complicated chemistry, but it can be broken down into an elementary analysis as follows:

Carbon	(C)	41.0%
Hydrogen	(H ₂)	4.5%
Oxygen	(O ₂)	37.0%
Water	(H ₂ O)	16.0% (Air dried)
Ash		1.5%

The brackets give the molecular formula. For example, C refers to 1 atom of carbon, which for carbon also happens to be one molecule. H₂ refers to one molecule of hydrogen, which consists of two atoms. There is also about 1% Nitrogen, which we will ignore.

The atomic weights of the different elements are as follows, and refer to the atomic weight of Hydrogen, the lightest element, which is 1.

H	1
C	12
O	16

Thus we get the molecular weight of carbon dioxide, CO₂, as 44 and carbon monoxide, CO, as 28.

44 grams of CO₂ and 28 grams of CO both have the same number of molecules, and therefore the same volume. A liter of CO₂ therefore weighs 44/28=1.57 times as much as a liter of CO at the same temperature.

Combustion reactions

During complete combustion, the following chemical reactions take place:

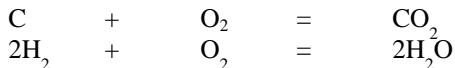

During incomplete combustion, we get the following:

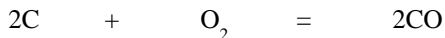

The CO can itself be combusted as follows:

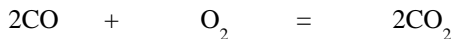

As wood is heated, it releases hydrocarbons in the form of volatiles or gases, and they are given the general molecular formula C_mH_n. The products from complete combustion of hydrocarbons are CO₂ and H₂O (water vapor or steam). During the charcoal phase, we're combusting C without any H₂, so we get CO₂ or CO, but no H₂O.

All of these reactions are exothermic, ie., they result in a conversion of chemical energy into heat, namely:

1kg C	+	2.67kg O ₂	=	3.67kg CO ₂	+ 32,000 BTU or 9.6 kWh
1kg C	+	1.33kg O ₂	=	2.33kg CO	+ 9,500 BTU or 2.9 kWh
1kg CO	+	0.57kg O ₂	=	1.57kg CO ₂	+ 9,500 BTU or 2.9 kWh
1kg H ₂	+	8.0kg O ₂	=	9.0kg O ₂	+ 135,000 BTU or 40.5 kWh

Once the chemical composition of a fuel is known, the above formulas can be used to calculate the heat content.

If we oven dry the wood, then it becomes 98.5% combustibles. We've taken out the water, and everything except the ash (and nitrogen) is combustible. The elementary analysis now becomes:

C	50.0%
H ₂	6.0%
O ₂	42.0%
Ash	2.0%

Combustion air

The theoretical combustion air requirement can be calculated from the chemical composition of the fuel.

With complete combustion and dry air:

$\text{Air}_{\text{th}} = 8.8 \text{ C} + 26.5 \text{ H}_2 - 3.3 \text{ O}_2 \text{ m}^3/\text{kg}$. This is also known as stoichiometric air.

Example

Let's run through an example:

Calculate the theoretical air requirement for wood combustion as well as the actual combustion air if the exhaust gas contains 10% CO_2 :

For wood with the following analysis:

C = 41%

H_2 = 4.5%

O_2 = 36%

N_2 = 1%

H_2O = 16%

Ash = 1.5%

Using our formula, stoichiometric, or theoretical air, becomes:

$$\begin{aligned}\text{Air}_{\text{th}} \dots\dots\dots &= 8.8 \times 0.41 + 26.5 \times 0.045 + 3.3 \times 0.36 \\ &= 3.60 \text{ m}^3/\text{kg}\end{aligned}$$

Excess air

In reality, more than the theoretical amount of air is required, since some air passes through the firebox without taking part in the combustion. This is called excess air.

Excess air = $\text{CO}_2 \text{ max.} / \text{CO}_2 \text{ measured}$

The maximum CO_2 possible in wood fuel flue gas is 20.9%

Returning to our example, the excess air is therefore $n = 20.9/10 = 2.09$, ie., 209% excess air.

Efficiency

Combustion efficiency measures how much of the wood's chemical energy is released during the burn. This is typically around 96 - 99% for most good masonry heaters. The chemical loss consists of unburned carbon monoxide and hydrocarbons that exit the chimney.

Heat transfer efficiency measures how good the appliance is at delivering the released energy to your house instead of out the chimney (stack). One way to define it is in terms of stack loss, something that can be measured with combustion testing equipment.

For wood, we will ignore the fact that the wood changes continuously in chemical composition as it goes from cordwood to charcoal, and assume an average composition. We've already dealt with the chemical loss due to incomplete combustion. There are three other types of stack loss.

Latent heat loss

This results from the fact that you are boiling off the water content of the wood into water vapor. It takes about 2,000 BTU to turn a kg of liquid water at 212°F to a kg of gaseous water at 212°F. Note that this loss does not involve a change of temperature, but rather a change of state from liquid to gas. It is termed latent heat, as opposed to sensible heat which is something you can sense as a temperature change. This is an unavoidable loss, unless you use a condensing chimney to reclaim the latent heat, as in a high efficiency gas furnace.

For wood that is at 20% moisture content, this ends up being about a 13% loss. One source of confusion with efficiency numbers and claims by manufacturers is that in Europe the latent heat loss is not counted. This means that if you see European literature on a stove claiming 80% efficiency, you have to subtract 13% to get a North American number.

Stack temperature

The gas leaving the chimney is above ambient temperature, which represents an efficiency loss. With 20% moisture wood and 200% excess air, you have to keep the gas temperature in the chimney above about 180°F to prevent condensation, which is undesirable unless your chimney is built specifically to handle it. You also need to maintain draft.

Excess air

If you are moving excess air through the system, it ends up at the stack temperature. Therefore, the more excess air, the higher the loss. With a masonry heater, we can pretty much pick whatever stack temperature we want in the design process. The main challenge is controlling excess air. Wood needs 200% to 300% excess air, or complete combustion will be hard to achieve and we will see elevated CO levels in the stack.

It is interesting to note that the theoretical maximum efficiency possible with a non condensing woodburning system burning wood at 20% moisture is about 80% overall efficiency.

Overall efficiency = Combustion efficiency × Heat transfer efficiency.

A very good real world number for a masonry heater is about 75% overall.

Emissions and flue deposits

If we cut back enough on combustion air, we will see a rise in emissions. The emissions question revolves around the subject of incomplete combustion. Incomplete hydrocarbon combustion gives rise to carbon monoxide (CO), soot (C), free hydrogen (H₂) and numerous tars and other organic compounds.

As chimney service professionals, you are all intimately familiar with certain of these compounds. At one end of the scale we have soot, which is pure carbon. It is a non volatile fluffy solid. At the other end of the scale we have complex organic chemicals. Some of these are volatile, which means we don't see them as they leave the chimney. Others are semi-volatile. They either condense after they leave the chimney into extremely small tar droplets, or smoke, or they condense before they leave the chimney and form a flue deposit. You all know that the most dangerous kind of flue deposit is shiny creosote, which is the most flammable because it is closest to the volatile end of the scale. It's pretty hard to light soot - it's more like trying to light a charcoal barbecue. This shouldn't surprise us, since charcoal and soot are different forms of the same chemical, carbon.

The woodsmoke that enters the atmosphere is considered to be a serious health hazard. I have seen one medical reference claiming that it is 40 times as harmful as cigarette smoke. If you turn down the air on an airtight woodstove enough, your woodfire goes from a flaming fire to a smoldering fire. Your emissions can increase by a factor of a hundred, i.e., 10,000%. Smoldering combustion should be avoided at all costs, because, aside from the pollution it inflicts on the environment, it gives woodburning a bad name.

Emissions are of great interest to the masonry heater builder. A masonry heater is by far the cleanest way to burn cordwood on a domestic scale, i.e. in batch mode from a cold start. Because we have heat storage at our disposal, we can use whatever burn rate we want.

Carbon monoxide (CO)

Carbon monoxide deserves a special mention. We have already seen how it arises from incomplete combustion and can contribute to stack loss and to emissions. CO is also a fuel, since we saw earlier that it contains 9,500 BTU of chemical energy per kilogram. At the tail end of a wood fire, during the charcoal stage, we are seeing CO combustion. We've already seen that charcoal is pure carbon, or C. It can burn either completely to CO₂, or partially to CO. The CO can then either burn to CO₂ or exit the chimney as a pollutant.

It is a potential safety hazard with all combustion appliances, including masonry heaters. Most masonry heaters have flue dampers, and if you close it before the fire is out, you can die from CO poisoning. CO is colorless, odorless, and potentially lethal. It is particularly dangerous because the ratio between low concentrations when you first start feeling physical effects such as headache and between fatal concentrations when you black out is only about 1:100. Fortunately, reliable CO detectors have recently become available at low cost. Everybody who has any combustion equipment in the house should have a CO monitor. As a masonry heater builder you need to tell your clients, in writing, to install a CO detector in the portion of the house that has the heater.

Combustion testing

Demonstration of a TESTO 342 combustion analyzer

This is a combustion gas analyzer that is manufactured in Germany and used there by many sweeps, stove builders and furnace technicians. I believe that before you are allowed to build a masonry heater in Germany you have to get an OK from the Bezirksschornsteinfegermeister, or district master chimney sweep, who will check out the venting setup and make sure that clearances are followed.

This particular instrument consists of the following:

- a flue gas probe
- a connecting hose
- a sample conditioning system
- a handheld battery powered analyzer
- an optional small remote controlled printer

It measures stack oxygen, stack CO, stack temperature and stack pressure (draft). The CO measurement is accurate to 20 PPM and you can use it to measure ambient CO in a house. It is programmed for 16 different fuels, including wood at 20% moisture, and can calculate stack loss directly. You can get an optional infrared remote printer that gives you a printed report.

I'll describe briefly what you would do to use it:

It is not designed for homeowner use and you have to read the manual carefully before using it, because it is a sensitive, not to mention expensive, piece of gear that will break if you don't follow the instructions.

Once you push the on button, it goes through a calibration phase. A pump turns on and pumps ambient air through the two electrochemical measuring cells. After about a minute, you follow the prompts on the LCD screen and adjust the oxygen number to read 21.0, which is ambient. It then jumps to a fuel selection sub-menu. Assuming you are just measuring one fuel, you don't have to change this.

You then insert the flue gas probe into the flue. Next, you turn on the pump and can read various screens full of information. You can program it to give up to 5 different screens. You then stop the pump and pull the flue gas probe out into fresh air. After you are done either printing out or writing down the reading, you need to turn the pump back on in order to flush out the measuring cells.

Table 6. Test summary from a typical Lopez Labs test

RUN No.	HK-D12
Wood Moisture.....	16.4
Total Weight.....	47.9
Kindling Weight.....	2
Number of Pieces.....	8
Fuel Surface/Vol.....	3.96
Run Length.....	1.5
Av. Stack Temp.....	401
Av. O2%.....	12.76
Av. CO%.....	0.12
Stack Temp. Factor.....	0.78
Stack Dilution Factor.....	2.57
Burn Rate dry kg/hr.....	11.39
Boiling of Water Loss.....	12.25
CO Loss %.....	2.03
HC Loss %.....	0.20
Dry Gas Loss %.....	14.83
Filter Catch gm.	0.0319
g/kg Condar.....	0.53
g/kg CO.....	17.93
Combustion Effic.....	97.76
Heat Trans. Effic.....	72.92
Overall Efficiency.....	71.29

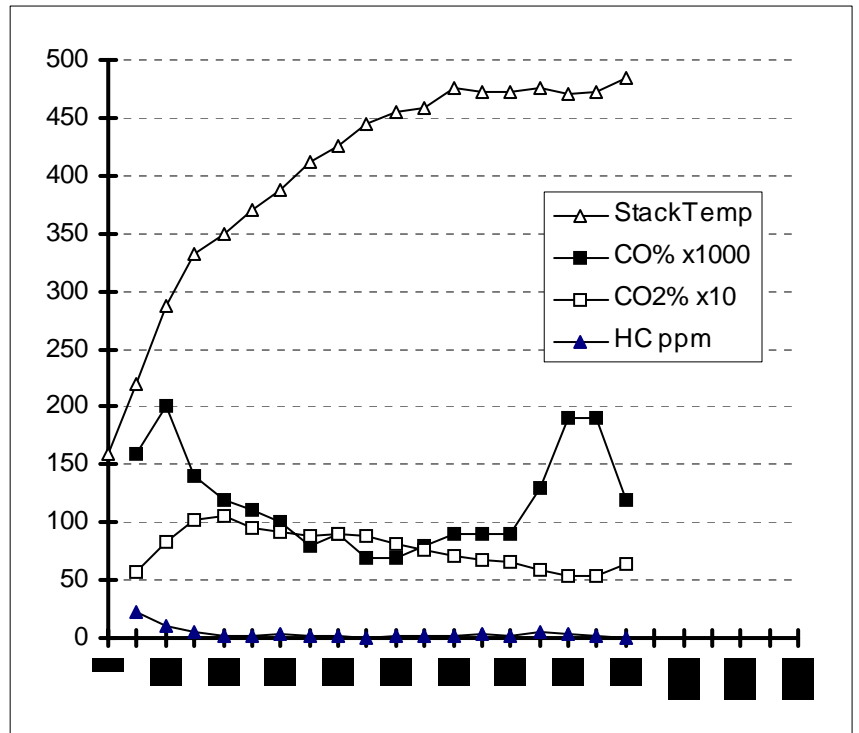

Figure 12. Flue gas analysis curves for a 1½ hr test run

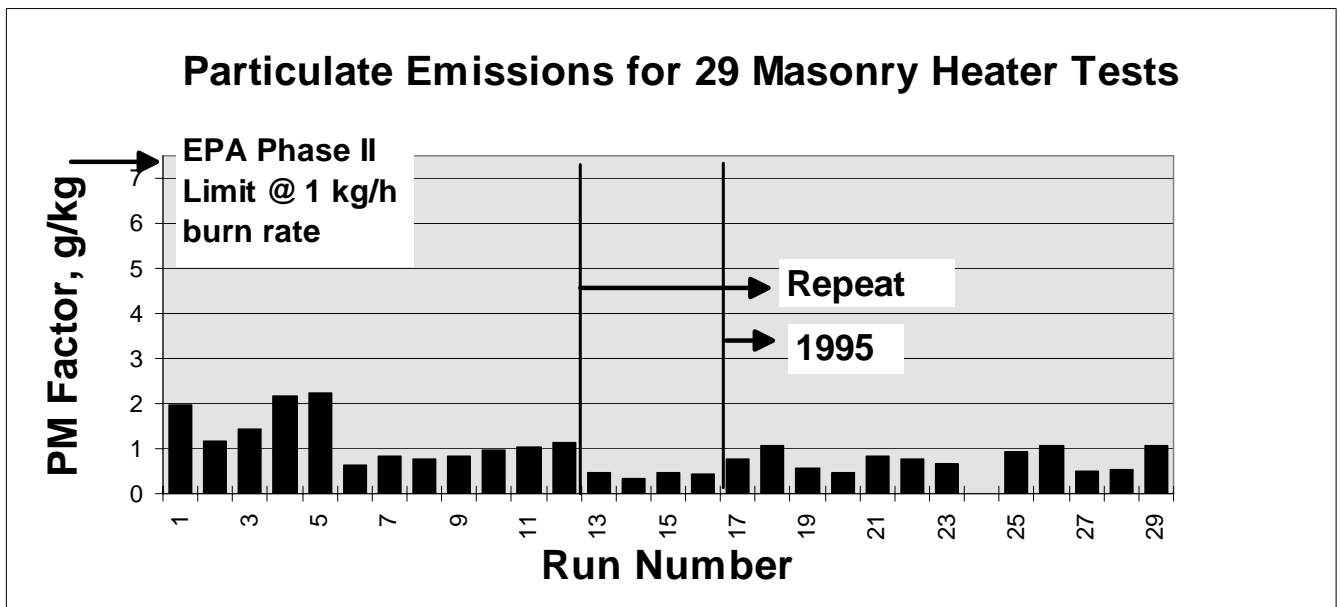

Figure 13. Lopez Labs 2 yr test results on one masonry heater

Masonry Heater Operating Principles

Burn cycle

Most North American heaters, as mentioned, are at the large end of the traditional scale. Most heaters are fired once per day. Burn cycle varies with owner lifestyle. With a typical couple where both people are away at work all day, the heater usually gets fired in the evening. Most heaters double as fireplaces, so heater owners get to see a real wood fire every night. The house is warm in the evening, overnight, and in the morning. As the house sits unoccupied, it slowly cools. A backup system can give the house a small boost just before its occupants arrive after work, and the cycle is repeated.

Options

Bakeovens can be incorporated into many heater types, and are getting very popular. Other common options are domestic hot water and heated sitting benches. With properly engineered heat exchangers, hot water heating systems such as radiant floors can also be driven.

Safety

CO danger has already been mentioned. It is worth repeating that reliable, inexpensive CO detectors have recently become available and should be mandatory equipment for owners of any combustion appliances. In the province of Ontario, they will soon become mandated in the provincial building code.

Maintenance and servicing

A properly designed, built and operated masonry heating system requires little service beyond a yearly checkup by a qualified chimney service person. A small amount of fly ash may need to be vacuumed from the channels. Our neighbour has a contraflow heater that we built for him in 1981, and he has never serviced it. There is no flue deposit at all, there is probably some fly ash, and all of the hardware is in mint condition after 15 years of normal use.

I have once seen creosote deposits in a masonry heater. The owners ran out of firewood the first winter and were cutting green trees and burning them right off the stump.

Some Masonry Heater Design and Construction Principles

Principal heater types

Among North American heater masons, there are generally regarded to be 4 principal heater types:

- Grundofen (German and Austrian)
- Contraflow (Finnish)
- Kakelugn (Swedish)
- Russian

The most commonly built type of heater is the contraflow, illustrated below:

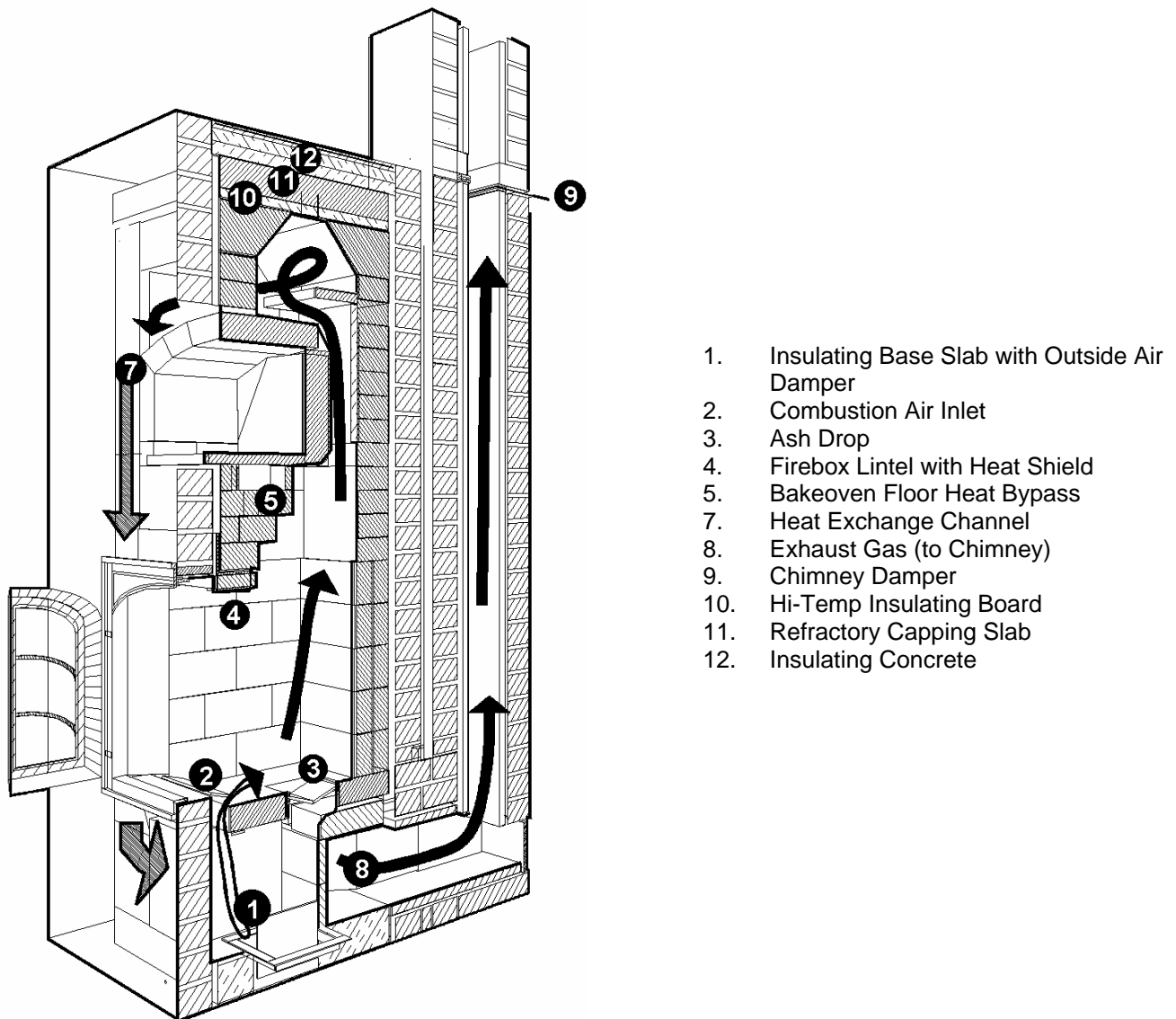

1. Insulating Base Slab with Outside Air Damper
2. Combustion Air Inlet
3. Ash Drop
4. Firebox Lintel with Heat Shield
5. Bakeoven Floor Heat Bypass
7. Heat Exchange Channel
8. Exhaust Gas (to Chimney)
9. Chimney Damper
10. Hi-Temp Insulating Board
11. Refractory Capping Slab
12. Insulating Concrete

Figure 14. Cutaway illustration of a contraflow heater.

There are a number of ways of constructing a masonry heater:

- Factory prefabricated heater (Tulikivi, Biofire). The complete heater including facing is assembled on site from prefabricated components.
- Factory prefabricated heater core (Tempcast, Envirotech). Heater core is assembled onsite from factory components. Heater facing is installed onsite.
- Hybrid cores (Heat-Kit, AlbieCore). Factory components are combined on site with standard refractory modules (firebricks). Heater facing is installed onsite.
- Handbuilt. Can be built from purchased plans (Maine Wood Heat Co.) or custom designed.
It should be noted that the first three options are relatively new. Until quite recently, all masonry heaters were handbuilt onsite and often custom-designed.

Heat output calculation

We will look at two ways of calculating masonry heater output:

Using the German system, we can first calculate what our heating output requirement is in BTU/hr or in KW. Next, we pick one of the four heater types. Table 2, below, gives us a design surface temperature, which is assumed as a constant. If we know the surface temperature, then it is a simple matter to look up the corresponding heat output, in BTU/ sq. ft. or kW/m². The required output is then kW/m² × m², i.e., we simply calculate the required masonry heater surface area.

A second method of calculating heat output is simpler and somewhat more practical for North America. We tend to build whole house heaters almost exclusively, whereas most of the traditional European heaters were room heaters. In other words, most of the categories of smaller heaters simply don't exist here.

For contraflow heaters, we can base our heat output calculation on several assumptions:

- Essentially, we try to build the highest output heater that we can. Oversizing is not an issue the way it is with airtight stoves, since heat output on a masonry heater is easily downsized simply by burning a smaller fuel charge. The charge itself is still burned at a high rate:
- the heater shape is somewhat fixed and less flexible than a heater without a glass fireplace door.
- we use the largest practical wood charge, about 60 lb. This gives us the largest practical firebox, 22½".
- we use the heaviest practical construction ("extra heavy" in the German system). This gives us the minimum practical sidewall thickness for a double skin contraflow heater, or about 6". Another way to look at it is that we are essentially trying for the highest surface temperature on a heavy heater.

Using the above rules of thumb, we end up with a heater that burns a 60 lb. wood charge and has about an 18 hr. cycle (time constant). If we assume a 75% overall efficiency, then 60 lb. of 20% moisture wood translates into about 300,000 BTU, or about 90 kWh of heat output.

Next, we can custom tailor our heat output by varying the firing cycle of the heater. We can burn 60 lb. once, twice, or three times per day. Three times per day is unusual, so we have a practical maximum output of 300,000 BTU × 2 or 600,000 BTU/day. Averaging this, we get 600,000/24 or 25,000 BTU/hr. (7.6kW) maximum design output.

In modern energy efficient housing, it is usually unnecessary to build a larger heater. There should always be a backup heating system. If it kicks on for, say, 5% of the heating season then it avoids the extra expense of an extra large heater.

Where it is necessary to have more output, there are several choices:

- Use a shorter firing cycle (8 hrs)
- Use a backup system
- Custom design a larger heater
- Use a standard heater with add-on storage. This is known as a heat battery. Make sure that it won't invalidate the core manufacturer's warranty. Heat batteries are usually custom designed to fit the situation.

Channel sizing and calculation

We will look at the German system for Grundofen calculation.

Terminology

Masonry heater terminology can sometimes be confusing. Many North American terms are borrowed from other languages due to the fact that there is no masonry heater tradition among English speaking peoples. There is some confusion in particular with German terms. The common term in Germany for a masonry heater is Kachelofen or “structural clay tile faced stove”. The term Grundofen (plural Grundöfen) is better, and literally means “ground stove”. This is to distinguish it from the Einsatzofen, or “insert stove”. The Einsatzofen consists of a metal stove insert and a Kachel or structural clay tile facing. North American stovemasons don’t consider this to be a true masonry heater, because it is mainly a convection system as opposed to a heat storing, radiant system. From our point of view, the more accurate German term for masonry heater is Grundofen. Very few stoves in North America use Kachel facings, so the term Kachelofen is not really accurate.

Design and Construction Sequence

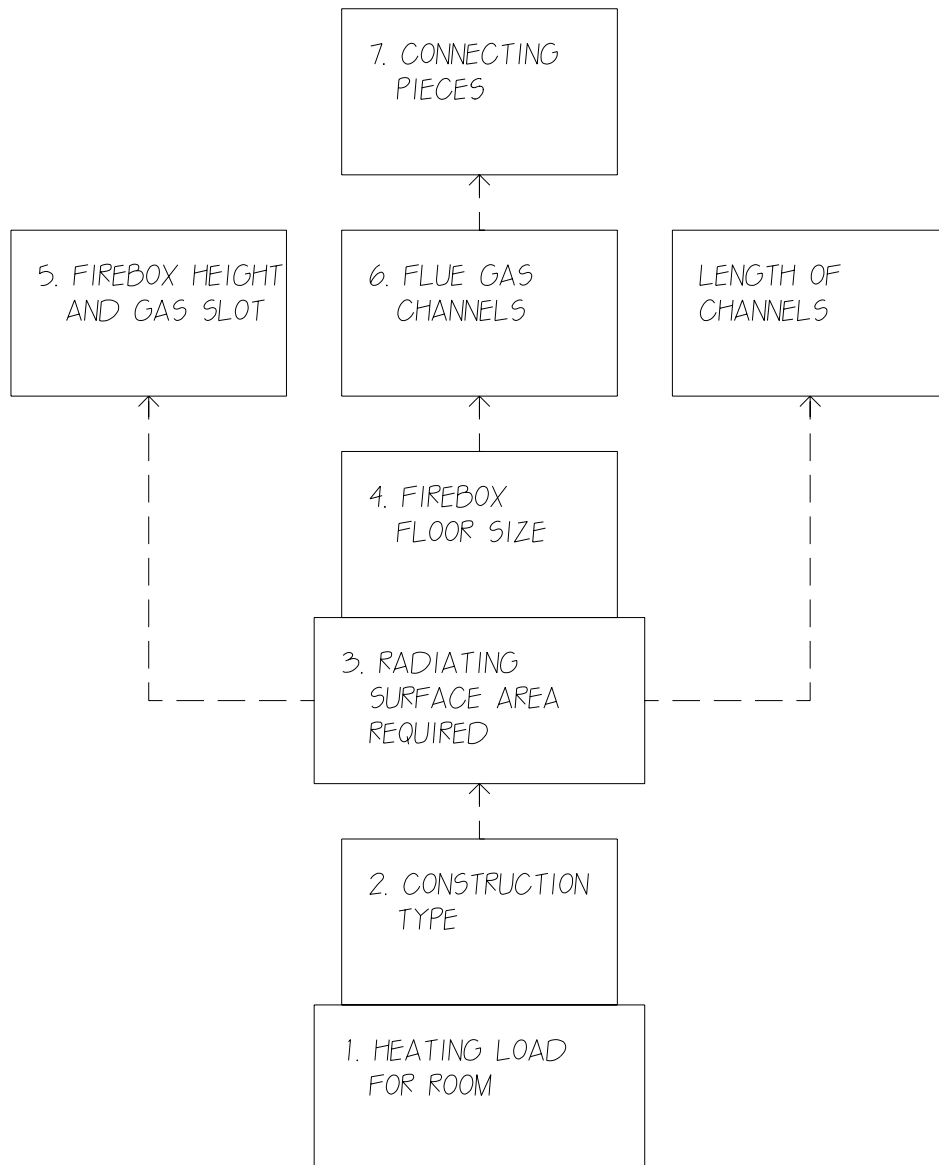

Figure 15. Construction sequence for Grundofen system

Construction Type**Table 7. Grundofen construction types and their characteristics**

Type	Heavy	Medium	Light
Prevailing climate usual for this type of construction	Heating intervals particularly long, very low temperatures	Heating intervals of medium length, low temperatures	short heating periods, mild temperatures
Heat storage capacity	Highest mass Highest storage capacity	Medium construction Good storage capacity	Light construction Adequate storage
Usual mode of operation	One large burn daily	One burn daily with one reloading	One burn daily with several reloadings
Type of heating cycle	A relatively long warmup time is followed by very long, steady heat output	A normal warmup time is followed by a long heat output	Room is warm after short warmup, but cools quicker unless stove is reloaded
Mass per KW output, kg	350	230	175
Average surface temperature, °F	147	176	194
Rated output, kW/m ²	0.7	0.93	1.16

Table 8. Cross sectional area of Grundofen heat exchange channel, cm²/kW - cordwood fired

Construction Type	First Channel	Last Channel
Heavy	130 to 150	90
Medium	110 to 130	90
Light	100 to 130	80

Refractory materials

Refractory means having the ability to withstand heat. Knowledge of refractory materials is not normally required for installers of factory made heaters. Installers are usually factory trained to install specific models of heaters, and are not necessarily stovemasons. For core-only systems, masonry skills are required to install custom facings. Sometimes the core is installed by a factory trained installer and the facing is done separately by a local mason.

A stovemason is capable of designing and handbuilding custom heaters to the customer's requirements. We've taken a brief look at how masonry heaters are designed and sized, and how some of the internal components are laid out.

Refractory materials is a large subject area. As chimney professionals, you are familiar with some of these.

Fired clay masonry units

An example of a fired clay masonry unit is an ordinary clay brick. It is composed of clay and has been fired in a kiln. It is different from a concrete brick, which is composed of portland cement and inert aggregate and is hardened by chemical action instead of by heat.

A firebrick is usually lighter in color than a common clay brick, which is usually red. The red color comes from iron, which is a common impurity in clay. Iron and other impurities such as lime lower the melting point of the clay. Fireclay is similar to ordinary clay except that it has fewer impurities. This gives it a higher melting point and allows it to withstand higher temperatures after it has been fired.

When you are looking for a good firebrick for use in building masonry heaters, you don't really care what temperature the brick is rated at. Even the lowest rated firebrick is capable of withstanding much higher temperatures than it will ever see in a masonry heater firebox. A super heavy duty industrial firebrick is not necessarily what you are looking for. These bricks are designed to be heated to high temperatures and kept there. This is a key point. In a masonry heater, although the firebrick doesn't have to withstand an extremely high temperature, it gets heated and cooled rapidly and often. This is termed thermal cycling, and is your main enemy as a stove mason. It is related the thermal shocking, which means changing the temperature of a material rapidly.

This can be illustrated by an example that you are all familiar with, the red clay flue liner. As chimney professionals you see a lot of cracked red clay flue liners. These liners are often made from fireclay, so they actually have no problem at all when it comes to handling high temperatures. You can heat them cherry red with no adverse effects, but you have to do it slowly. If you heat or cool them rapidly, they crack. They can take heat but they can't take thermal shock.

Clay flue liners crack because of their geometry. Clay has a coefficient of thermal expansion, which means that it expands by 1% for every 100 degrees Centigrade temperature rise. Fired clay is not very flexible, so if you heat a flue liner unevenly parts of it will expand faster than other parts, causing it to crack. Because the liner is relatively thin, it is easy to get hot spots.

A second property of clay that affects its thermal cycling properties is its chemical composition. The two main constituents of clay are silica and alumina. Pure alumina is white and has a very high melting point. Porcelain is an example of a high alumina clay. Silica can cause problems in refractories. It undergoes a reversible change in crystal structure known as a quartz inversion at 573°C accompanied by a change in volume.

Castable refractories

Castable refractories are used to make what amounts to high temperature concrete. An example from the chimney lining trade would be the various pumped liner systems. Castable refractory, like ordinary concrete, consists of an aggregate and a binder. In concrete, the binder is portland cement and the aggregate is sand and gravel. In castable refractory, the most common binder is calcium aluminate cement, also known as fondue cement or lumnite. You can buy it in a 90 lb bag just like portland cement, and it has some similar properties and uses. In fact, non-soluble refractory mortar, which has become mandated in NFPA 211 and some state building codes for joining flue liners, is basically a mixture of calcium aluminate cement and sand. The aggregate in castable refractory usually is crushed firebrick or some other refractory mineral substance.

Refractory mortars

Refractory mortars are typically used for setting refractory standard modular unit masonry (firebricks). Non-soluble mortars have already been mentioned, and are used for joining flue liners and joining large precast refractory modules.

Firebricks, if they are not going to be exposed to water as in a chimney flue, are normally set in clay mortar, either heat setting or air setting. Heat setting mortar consists solely of clay, and sets only after the clay has been taken up past its fusing temperature. This will never happen in a domestic scale masonry heater, except perhaps in portions of the firebox and only if low melting point clays (plastic earthenware clays) were used. Air setting refractory mortars such as Sairset from A.P.Green consist of fireclay with sodium silicate added. Sodium silicate is also known as water glass. It is used by potters as a defloculant, which means that it keeps clay particles in suspension, giving the clay a slimey feel. It is also the material that you

buy as stove gasket glue in small bottles. It's about \$10 per gallon at A.P. Green. It sets by drying, and remains somewhat water soluble after it has set. This is a problem in chimney flue liners, but not in masonry heaters since they never get wet.

Setting firebricks

As mentioned, firebricks are normally set in refractory clay mortar, either heat set or air set. Airsets are commonly used on masonry heaters but non-airsets also to some degree. Firebricks can be trowelled or dipped. Sairset comes in the bucket at trowelling consistency. All commercial refractory work is done by dipping. It is extremely fast, since firebricks are very dimensionally consistent and can therefore be set with very thin joints. In order to dip firebricks, you need to thin the refractory mortar by adding water. It has the right consistency when a dry firebrick laid flat on the surface sinks about halfway.

Insulating Refractories

There are a number of types of insulating refractories. They include:

- insulating castable refractories
- ceramic blanket and ceramic paper
- refractory insulating board or millboard

Other Refractories

Soapstone is a unique refractory and masonry material. Compared to a pound of concrete, a pound of soapstone can store approximately 20% more heat. Its main distinctive thermal property is that it has about 4 times the conductivity of concrete or about 6 times the conductivity of soft clay brick. Another way of saying this is that its R value is 1/4 that of concrete. It is somewhat similar to a metal in this respect. This means that a soapstone heater of equivalent mass will heat up faster on the outside surface and reach a higher surface temperature, due to the high conductivity. On the other hand, the higher rate of heat transfer to the room also means that it cools down faster than other masonry materials. Understanding the thermal properties of soapstone gives the heater mason an additional way to handle unusual design requirements when they arise. For example, we use soapstone heat transfer plates in castable refractory bakeoven floors to even out cool spots. A nice feature of soapstone is that it can be carved quite easily.

Expansion joints

The quickest way to go out of business in the masonry heater business is to build heaters that crack their facings. When fired, the interior of a heater, particularly the firebox, heats up first and expands. If the proper expansion joints are not left at appropriate locations between the heater core and the facing, the facing will crack. This is guaranteed, and has put a lot of new heater builders out of business over the years. You can wrap the core with mineral wool, but this will compromise performance unless it is very thin. Don't use an airspace filled with sand, either. Expansion joints are fairly simple once you learn exactly where you need to put them.

Hardware

Metal hardware for masonry heaters should be designed for long service. Firebox doors and frames should be cast iron. Only ceramic glass should be used.

Finishes

Finished can be almost anything within the entire huge range of masonry. Most popular in North America are brick, stucco, stone and tile. Some examples are given in the slideshow.

Codes and Standards

If you are building a masonry heater, your client typically will have to deal with a local building inspector and also his/her insurance company. The insurance company will usually want to know that you are installing a “listed appliance”, and/or that you have a building permit.

A listed appliances carries a label from a recognized testing laboratory stating that it has been safety tested for clearances to combustibles in accordance with the applicable UL (Underwriters Laboratories) standards. The clearances will be spelled out on the tag. Listing is possible with factory-made heaters, but not practical for site-built units. These fall under the building code, which carries provisions for clearances to combustibles for masonry fireplaces and chimneys.

Very few code jurisdictions currently recognize masonry heaters specifically. One exception is the state of Washington. The nearest applicable provisions are usually the masonry fireplace and chimney sections of the locally recognized code, which often references NFPA 211 (the National Fire Protection Association standard).

Masonry fireplaces codes typically specify the following:

Clearances to combustibles from:

- the firebox opening
- cleanouts
- the masonry itself

Materials and minimum thicknesses for

- the firebox
- a non-combustible hearth extension
- other surfaces

If a prefabricated non-masonry chimney will be used, it may be necessary to find a connector listed for attachment to masonry.

To address the lack of specific standards for masonry heater construction in North American building codes, an ASTM task group was formed about 10 years ago. ASTM is the world’s largest consensus standards organization. It differs from UL in that standards development is an open process and anybody has the right to have their particular concerns addressed before a standard can be voted on.

ASTM Standard Guide E 1602 - 94 was passed in 1994 and is titled “Construction of Solid Fuel Burning Masonry Heaters”.

Highlights of the ASTM Standard Guide for Construction of Solid Fuel Burning Masonry Heaters

Scope

- Provides dimensions for sitebuilt masonry heater components.
- Provides clearances that have been derived by experience.
- Does not apply to components that have been safety tested and listed.

Definitions

Gives definitions for masonry heater specific terminology.

Significance and Use

- “4.1 This guide can be used by code officials, architects, and other interested parties to evaluate the design and construction of masonry heaters. It is not restricted to a specific method of construction, nor does it provide all specific details of construction of a masonry heater. This guide does provide the principles to be followed for the safe construction of masonry heaters.”
- Not intended to be a complete set of construction instructions.
- “4.3 ... construction shall be done by or under the supervision of a skilled and experienced masonry heater builder.”

Requirements

- Clearances to combustibles
- Minimum dimensions and materials for various heater elements
- Other construction details

Typical Masonry Heater Types

- Lists 5 masonry heater types with example illustrations

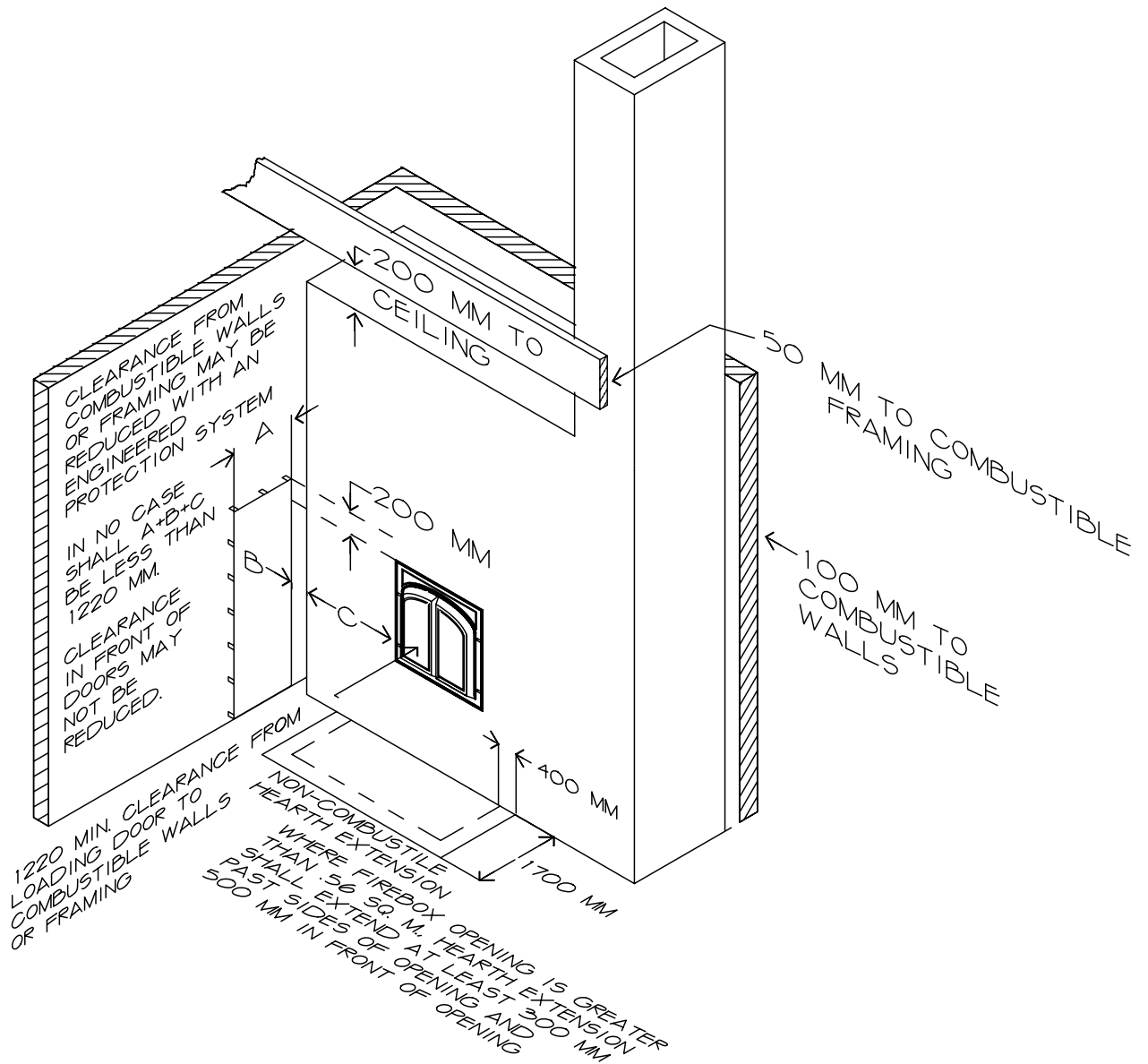

Figure 16. ASTM clearances to combustibles for masonry heaters

Slide Show

- Examples of heater design and construction
- Manufactured vs. handbuilt systems
- Marketing examples

Practical Demonstration

- Layout and construction of the bottom end of a contraflow heater
- Firebrick techniques

Question Period and Discussion